

Fanvil Product User Manual

IP-Gateway

Model: A2



Version: V1.0.90.16

© 2005 Fanvil technology Co., Ltd

All rights reserved.

This document is supplied by Fanvil Technology Co., Ltd, No part of this document may be reproduced, republished or retransmitted in any form or by any means whatsoever, whether electronically or mechanically, including, but not limited to, by way of photocopying, recording, information recording or through retrieval systems, without the express written permission of Fanvil Technology Co., Ltd. Fanvil Technology Co., Ltd reserves the right to revise this document and make changes at any time and without the obligation to notify any person and/or entity of such revisions and/or changes. Product specifications contained in this document are subject to change without notice.



Safety Notices

Please read the following safety notices before installing or using this gateway. They are crucial for the safe and reliable operation of the device.

- Please use the external power supply that is included in the package. Other power supplies may cause damage to the device, affect the behavior or induce noise.
- Before using the external power supply in the package, please check with home power voltage. Inaccurate power voltage may cause fire and damage.
- Please do not damage the power cord. If power cord or plug is impaired, do not use it, it may cause fire or electric shock.
- The plug-socket combination must be accessible at all times because it serves as the main disconnecting device.
- Do not drop, knock or shake it. Rough handling can break internal circuit boards.
- Do not install the device in places where there is direct sunlight. Also do not put the device on carpets or cushions. It may cause fire or breakdown.
- Avoid exposure the gateway to high temperature, below 0°C or high humidity. Avoid wetting the unit with any liquid.
- Do not attempt to open it. Non-expert handling of the device could damage it. Consult your authorized dealer for help, or else it may cause fire, electric shock and breakdown.
- Do not use harsh chemicals, cleaning solvents, or strong detergents to clean it. Wipe it with a soft cloth that has been slightly dampened in a mild soap and water solution.
- When lightning, do not touch power plug or device line, it may cause an electric shock.
- Do not install this device in an ill-ventilated place.
- You are in a situation that could cause bodily injury. Before you work on any equipment, be aware of the hazards involved with electrical circuitry and be familiar with standard practices for preventing accidents.

Table of Content

1. WELCOME TO THE A2 TWO-PORT GATEWAY	5
1.1. Package Contents.....	5
2 UNDERSTANDING OF A2 TWO-PORT GATEWAY.....	6
2.1. The positive of A2 two-port gateway	6
2.2. Indicator signs	7
2.3. Connector description.....	7
3. GETTING STARTED	9
3.1. Connect the power and network	9
3.1.1. Connect the network.....	9
3.1.2. Connect the power	10
4. BASIC PHONE OPERATION OF A2 TWO-PORT GATEWAY	11
4.1. Call transfer	11
4.2. Call hold	11
5. WEB CONFIGURATION.....	12
5.1. Introduction of configuration.....	12
5.1.1. Ways to configure	12
5.1.2. Password Configuration	12
5.2. Setting via web browser	12
5.3. Configuration via WEB	13
5.3.1. BASIC	13
5.3.1.1. Status	13
5.3.1.2. Wizard.....	13
5.3.2. Network	15
5.3.2.1. WAN Config.....	15
5.3.2.2. LAN Config.....	17
5.3.2.3. Qos Config	18
5.3.2.4. Service Port.....	20
5.3.2.5. DHCP SERVER.....	21
5.3.2.6. NTP	22
5.3.3. VOIP	22
5.3.3.1. SIP Config	22
5.3.3.2. Stun Config.....	26
5.3.3.3. DIAL PEER setting.....	27
5.3.4. Phone	31
5.3.4.1. DSP Config.....	31
5.3.4.2. Call Service	32
5.3.4.3. Digital Map Configuration	34
5.3.5. Maintenance.....	35
5.3.5.1. Auto Provision	35
5.3.5.2. Syslog Config	36
5.3.5.3. Config Setting	37
5.3.5.4. Update	38

5.3.5.5. Account Config.....	38
5.3.5.6. Reboot	39
5.3.6. Security	40
5.3.6.1. MMI Filter.....	40
5.3.6.2. Firewall	41
5.3.6.3. NAT Config.....	42
5.3.6.4. VPN Config.....	44
5.3.7. Logout	45
6. APPENDIX	46
6.1. SPECIFICATION.....	46
6.1.1. HARDWARE.....	46
6.1.2. VOICE FEATURES.....	46
6.1.3. NETWORK FEATURES.....	46
6.1.4. MAINTENANCE AND MANAGEMENT	47
6.2. PARTICULARLY SUITABLE FOR A2 TWO-PORT GATEWAY.....	47
6.3. COMMON PROBLEMS	47

1. Welcome to the A2 two-port gateway

1.1. Package Contents

Please check your product packaging, it includes:

- 1. One A2 two-port gateway**
- 2. A group of cable**
- 3. A power adapter**

NOTE: if you use the non-A2 two-port gateway comes with a power adapter, two-port gateway may cause damage or other injury. Specifications for the power adapter may different between the different shipment areas. If the power adapter provided with the product can not be used locally, please consult your local dealer.

- 4. User manual**

2 Understanding of A2 two-port gateway

A2 two-port gateway IP-based voice media access device is designed for operators, enterprises, residential users, and residential VoIP solution to provide network equipment. A2 two-port gateway into the analog voice information transmitted over IP networks, which use IP networks to transmit voice. It is full compliance with the SIP protocol standard, with the market most other SIP compliant devices and server-side.

The gateway will play Internet network (either public network or private network) connecting with the public telephone network bridge. It provides two FXS analog voice interfaces, used for ordinary small business PBX or gateway (PBX).

This site using the most advanced voice processing technologies, such as advanced voice compression standards, echo cancellation, dynamic voice detection, silence detection, ensuring Quality of Service (QoS), and voice quality comparable to regular PSTN phone.

In addition, A2 two-port gateway also integrates a small router function. WEB comes through the gateway configuration page, simply configure the network parameters, can achieve multiple computers and network equipment, broadband access, ideal for small office and home users.

Because this site has a wealth of features and related detailed configuration options, in your call to enjoy a stress free before you know your A2 two-port gateway.



2.1. The positive of A2 two-port gateway

2.2. Indicator signs



Name	Meaning	Description
POWER	Power LED	Always light, has power, you can start using the A2 two-port gateway.
FXS1	Phone work status lights	Show the status of the phone under the port 1. No phone or hang up: Off; pick up: always.
FXS2	Phone work status lights	Show the status of the phone under the port 2. No phone or hang up: Off; Pick up: always.
WAN	WAN network interface lights	Indicator light, WAN port connected to the network. Flashing: Data transfer.
LAN	LAN network interface lights	Indicator light, LAN port connected to the network. Flashing: Data transfer.

2.3. Connector description

Name	Meaning	Description
POWER	Power switch	Output:12VDC, 500mA.
FXS1	FXS1 Interface	Ordinary telephone connection, or switch into the line.
FXS2	FXS2 Interface	Ordinary telephone connection, or switch into the line.
LAN	Network Interface	10/100M Adaptive connected PC.
WAN	Network Interface	10/100M Adaptive connected to the RJ45 port of Internet.

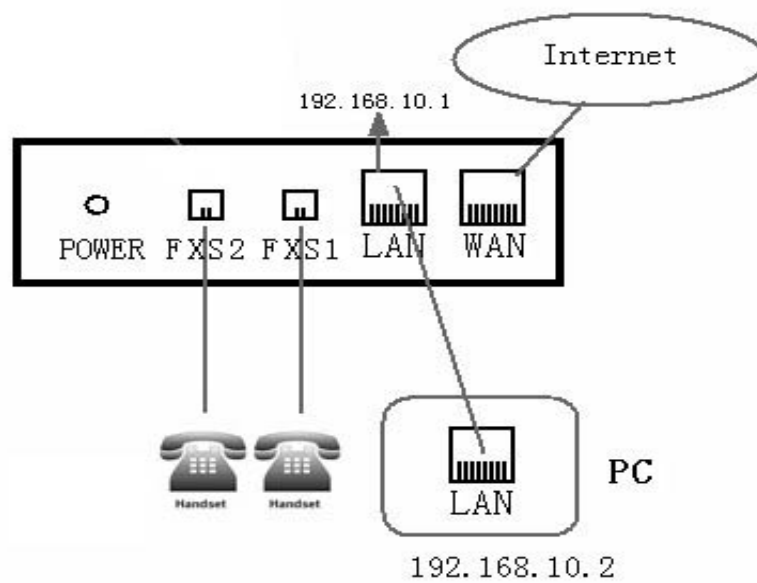

A2 two-port gateway with two network interface itself: WAN port and LAN port, you can use the Internet connection into the WAN port or LAN port. Read the manual carefully of “Safety” before inserting the power

3. Getting Started

Before you start using the A2 two-port gateway, please install the following:

3.1. Connect the power and network

3.1.1. Connect the network

During this step, make sure your environment already have broadband Internet access capability.

1. Broadband Router

Direct network connection—by this method, you need at least one available Ethernet port in your workspace. Use the Ethernet cable in the package to connect WAN port of A2 two-port gateway to the Ethernet port in your workspace. Since this gateway has router functionality, whether you have a broadband router or not, you can make direct network connect. The following two figures are for your reference.

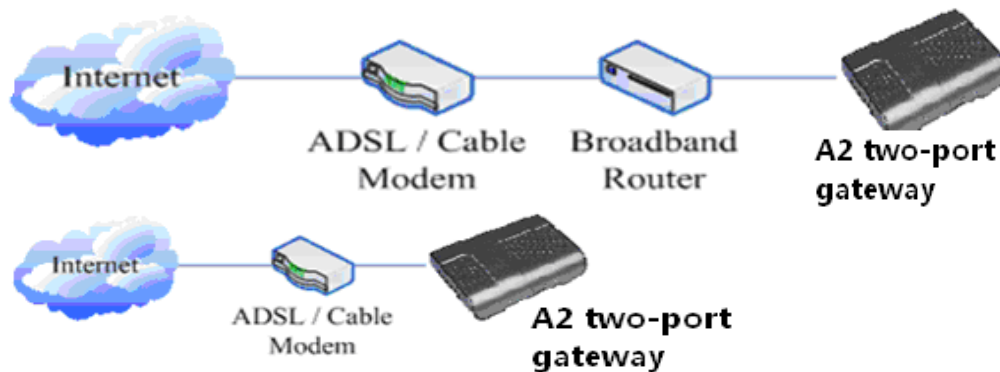

2. as a broadband router

Use this method if you have a single Ethernet port in your workspace with your desktop computer already connected to it. First, disconnect the Ethernet cable from the computer and attach it to the WAN port of gateway. Next, use the Ethernet cable in the package to connect LAN port of gateway to your desktop computer. Your IP Phone now shares a network connection with your computer. The following figure is for your reference.

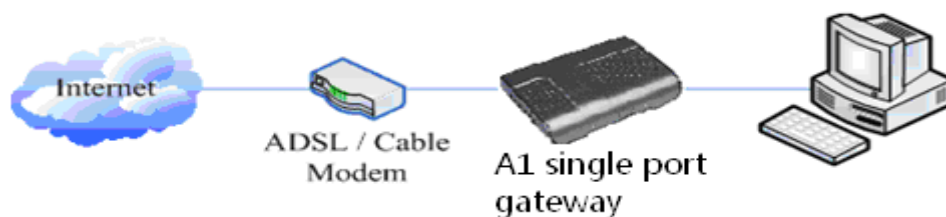

3.1.2. Connect the power

During this step, make sure your power supply connector and A2 two-port gateway outlet match, while A2 is also in line voltage and current required for a two-port gateway.

- 1. The transformer connected to the DC port on the back of A2 two-port gateway POWER jack.**
- 2. The AC adapter plug to an electrical outlet, A2 two-port gateway boot.**
- 3. At this point all of your lights (except the POWER indicator) will flash together. After booting, you will hear popping sounds, and then the indicator light is lit according to your current configuration corresponding light. (If your light is not normal, you need to further configure your network connection mode).**
- 4. If you login on the gateway server, then you can start calling.**

4. Basic phone operation of A2 two-port gateway

Since there are two FXS interfaces on the A2 two-port gateway, and the two interfaces are independent, so the phones under the FXS1 and FXS2 have the same operation. The phones under the two ports can be used as two separate telephones at the same time. The following operations are applicable to the phones under the FXS1 and FXS2.

4.1. Call transfer

- **Blind Transfer**

During a call, press FLASH (Flash) key, enter the number to be transferred **【*】** add and press **【#】** key to confirm, you can transfer the current call to third parties. (To use this feature, you must enable the gateway of the Call Waiting and Call Transfer function)

- **Attended Transfer**

During a call, press FLASH (Flash) key, enter the number waiting to be transferred connected, directly hang up, you can transfer successfully. (To use this feature, you must enable the gateway of the Call Waiting and Call Transfer function)

NOTE:1, Call Transfer must call in two cases all the way is free for operation;
2, Gateway (transfer side) and the establishment of phone A calls phone C gateway and then create a call, hang up the phone A, this time the gateway can also initiate the transfer.

3, your VoIP traffic services providers need to support (RFC3515), this feature to work correctly.

4.2. Call hold

- **Call Hold and set aside**

During a call you can press FLASH (FLASH) button and enter the number to dial and press **【#】** key to ensure

Recognition, can retain the current state of the call with third-party calls. If you press the FLASH (Flash) key, you can switch back. You also can send and receive on one side, then the party can not be retained to hear your conversation, the speaker you can not. During a call if you press **【*】** operation, will enter the three-way calling mode. (To use this feature, you must enable the gateway of the Call Waiting feature, you must achieve three-way calling mode to start the gateway Three Way Call function)

- **Call on hold and accept call waiting**

In normal conversation, a third party dial-in, the handset will beep ~ beep ~ tips coming, you can use FLASH (Flash) button to accept call waiting. If you press this

button again, you can switch back. You also can send and receive on one side, then the party can not be retained to hear your conversation, the speaker you can not. (To use this feature, you must enable the gateway of the Call Waiting feature)

5. Web configuration

5.1. Introduction of configuration

5.1.1. Ways to configure

A2 two-port gateway has two different ways to different users.

- Use web browser (recommendatory way) .
- Use telnet with CLI command.

5.1.2. Password Configuration

There are two levels to access to gateway: root level and general level. User with root level can browse and set all configuration parameters, while user with general level can set all configuration parameters except SIP (1-2) that some parameters can not be changed, such as server address and port. User will has different access level with different username and password.

- Default user with general level :
 - ◆ username : guest
 - ◆ password : guest
- Default user with root level :
 - ◆ username : admin
 - ◆ password : admin

5.2. Setting via web browser

When this gateway and PC are connected to network, enter the WAN port IP address of the gateway as the URL (e.g. `http://xxx.xxx.xxx.xxx/` or `http://xxx.xxx.xxx.xxx:xxxx/`).

Gateway IP address can be received by dialing # * 111.

The login page is shown as below



The screenshot shows a login page with a light gray background. It contains two text input fields: the first is labeled "Username:" and the second is labeled "Password:". Below these fields is a button labeled "Logon".

5.3. Configuration via WEB

5.3.1. BASIC

5.3.1.1. Status

BASIC			
STATUS		WIZARD	
Network			
WAN		LAN	
Connect Mode	DHCP	IP Address	192.168.10.1
MAC Address	00:a8:59:c3:42:9a	DHCP Server	ON
IP Address	192.168.1.17		
Gateway	192.168.1.1		
Phone Number			
SIP LINE 1	@ :5060	Unapplied	
SIP LINE 2	@ :5060	Unapplied	
Version: VOIP Gateway V1.0.57.16 Sep 9 2010			

Status

Field name	Explanation
Network	Shows the configuration information on WAN and LAN port, including the connect mode of WAN port (Static, DHCP, PPPoE), MAC address, the IP addresses of WAN port and LAN port, ON or OFF of DHCP mode of LAN port.
Phone Number	Shows the phone numbers provided by the SIP LINE 1-2 servers. The last line shows the version number and issued date.

5.3.1.2. Wizard

BASIC	
STATUS	
WIZARD	
Network Mode Select	
Static IP MODE	<input type="radio"/>
DHCP MODE	<input checked="" type="radio"/>
PPPoE MODE	<input type="radio"/>
<input type="button" value="BACK"/> <input type="button" value="NEXT"/>	

Wizard

Field Name	Explanation
------------	-------------

Static IP MODE	<input checked="" type="radio"/>
DHCP MODE	<input type="radio"/>
PPPoE MODE	<input type="radio"/>

Please select the proper network mode according to the network condition.

A2 gateway provide three different network settings:

- **Static:** If your ISP server provides you the static IP address, please select this mode, and then finish Static Mode setting. If you don't know about parameters of Static Mode setting, please ask your ISP for them.
- **DHCP:** In this mode, you will get the information from the DHCP server automatically; need not to input this information artificially.
- **PPPoE:** In this mode, you must input your ADSL account and password.

You can also refer to 3.2.1 to quick set your network.

Choose Static IP MODE, click **[NEXT]** can config the network and SIP(default SIP1) simply, also can browse too. Click **[BACK]** can return to the last page.

Static IP Set	
Static IP Address	192.168.1.179
Netmask	255.255.255.0
Gateway	192.168.1.1
DNS Domain	
Primary DNS	202.96.134.133
Alter DNS	202.96.128.68

Static IP Address	Input the IP address distributed to you.
Netmask	Input the Netmask distributed to you.
Gateway	Input the Gateway address distributed to you.
DNS Domain	Set DNS domain postfix. When the domain which you input can not be parsed, gateway will automatically add this domain to the end of the domain which you input before and parse it again.
Primary DNS	Input your primary DNS server address.
Alter DNS	Input your alternate DNS server address.

SIMPLE SIP SET	
Display Name	
Server Address	192.168.1.2
Server Port	5060
User Name	2113
Password	••••
Phone Number	2113
Enable Register	<input checked="" type="checkbox"/>

Display Name	Set the display name.
Server Address	Input your SIP server address.
Server Port	Set your SIP server port.
User Name	Input your SIP register account name.
Password	Input your SIP register password.
Phone Number	Input the phone number assigned by your VOIP service provider.

Enable Register Start to register or not by selecting it or not.

WAN	
Connect Mode	Static
Static IP Address	192.168.1.179
Gateway	192.168.1.1
SIP	
Register Server	192.168.1.2
Account/User Name	2113
PhoneNumber	2113
Register	ON
<input type="button" value="BACK"/> <input type="button" value="Finish"/>	

Display detailed information that you manual config.

Choose DHCP MODE, click **[NEXT]** can config SIP(default SIP1) simply, also can browse too. Click **[BACK]** can return to the last page. Like Static IP MODE.

Choose PPPoE MODE, click **[NEXT]** can config the PPPoE account/password and SIP(default SIP1) simply, also can browse too. Click **[BACK]** can return to the last page. Like Static IP MODE.

PPPOE Set	
PPPOE Server	ANY
Username	user123
Password	*****

PPPoE Server It will be provided by ISP.

Username Input your ADSL account.

Password Input your ADSL password.

Notice: Click **[Finish]** button after finished your setting, gateway will save the setting automatically and reboot, After reboot, you can dial by the SIP account.

5.3.2. Network

5.3.2.1. WAN Config

NETWORK	
WAN LAN QOS SERVICE PORT DHCP SERVER NTP	
WAN Status	
Active IP	192.168.1.17
Current Netmask	255.255.255.0
Current Gateway	192.168.1.1
MAC Address	00:a8:59:c3:42:9a
Get MAC Time	20100930
WAN Setting	
Static <input type="radio"/>	DHCP <input checked="" type="radio"/>
PPPOE <input type="radio"/>	
<input checked="" type="checkbox"/> Obtain DNS server automatically	
<input type="button" value="APPLY"/>	

WAN Config

Field Name	explanation
------------	-------------

WAN Status	
Active IP	192.168.1.17
Current Netmask	255.255.255.0
Current Gateway	192.168.1.1
MAC Address	00:a8:59:c3:42:9a
Get MAC Time	20100930

Active IP	The current IP address of the gateway.
Current Netmask	The current Netmask address.
MAC Address	The current MAC address of the gateway.
Current Gateway	The current Gateway IP address.
Get MAC Time	Shows the time of getting MAC address

WAN Setting		
Static <input checked="" type="radio"/>	DHCP <input type="radio"/>	PPPOE <input type="radio"/>

Please select the proper network mode according to the network condition.

A2 two-port gateway provide three different network settings:

- **Static:** If your ISP server provides you the static IP address, please select this mode, and then finish Static Mode setting. If you don't know about parameters of Static Mode setting, please ask your ISP for them.
- **DHCP:** In this mode, you will get the information from the DHCP server automatically; need not to input this information artificially.
- **PPPoE:** In this mode, your must input your ADSL account and password. You can also refer to 3.2.1 Network to quick set your network.

Obtain DNS server automatically Select it to use DHCP mode to get DNS address, if you don't select it, you will use static DNS server. The default is selecting it.

Static IP Address	192.168.1.178
Netmask	255.255.255.0
Gateway	192.168.1.1
DNS Domain	
Primary DNS	202.106.195.68
Alter DNS	202.96.128.68
<input type="button" value="APPLY"/>	

If you use static mode, you need set it.

IP Address	Input the IP address distributed to you.
Netmask	Input the Netmask distributed to you.
Gateway	Input the Gateway address distributed to you.
DNS Domain	Set DNS domain postfix. When the domain which you input can not be parsed, gateway will automatically add this domain to the end of the domain which you input before and parse it again.
Primary DNS	Input your primary DNS server address.
Alter DNS	Input your alternate DNS server address.

PPPOE Server	ANY
Username	user123
Password	*****

If you uses PPPoE mode, you need to make the above setting.

PPPoE Server	It will be provided by ISP.
Username	Input your ADSL account.
Password	Input your ADSL password.

Notice:

- 1) Click “Apply” button after finished your setting, IP gateway will save the setting automatically and new setting will take effect.
- 2) If you modify the IP address, the web will not response by the old IP address. Your need input new IP address in the address column to logon in the web.
- 3) If networks ID which is DHCP server distributed is same as network ID which is used by LAN of system, system will use the DHCP IP to set WAN, and modify LAN’s networks ID(for example, system will change LAN IP from 192.168.10.1 to 192.168.11.1) when system uses DHCP client to get IP in startup; if system uses DHCP client to get IP in running status and network ID is also same as LAN’s, system will refuse to accept the IP to configure WAN. So WAN’s active IP will be 0.0.0.0

5.3.2.2. LAN Config

NETWORK

WAN	LAN	QOS	SERVICE PORT	DHCP SERVER	NTP
LAN Set					
LAN IP	192.168.10.1				
Netmask	255.255.255.0				
DHCP Service	<input checked="" type="checkbox"/>				
NAT	<input checked="" type="checkbox"/>				
Bridge Mode	<input type="checkbox"/>				
<input type="button" value="APPLY"/>					

LAN Config

Field name	explanation
LAN IP	Specify LAN static IP.
Netmask	Specify LAN Netmask.
DHCP Service	Select the DHCP server of LAN port or not. After you modify the LAN IP address, gateway will amend and adjust the DHCP Lease Table and save the result amended automatically according to the IP address and Netmask. You need restart the gateway and the DHCP server setting will take effect.
NAT	Select NAT or not.
Bridge Mode	Select Bridge Mode or not: If you select Bridge Mode, the gateway will no longer set IP address for LAN physical port, LAN and WAN will join in the same network. Click “Apply”, the gateway will reboot.

Notice: If you choose the bridge mode, the LAN configuration will be

disabled.

5.3.2.3. Qos Config

The gateway support 802.1Q/P protocol and DiffServ configuration. VLAN functionality can use different VLAN IDs by setting signal/voice VLAN and data VLAN. The VLAN application of this device is very flexible.

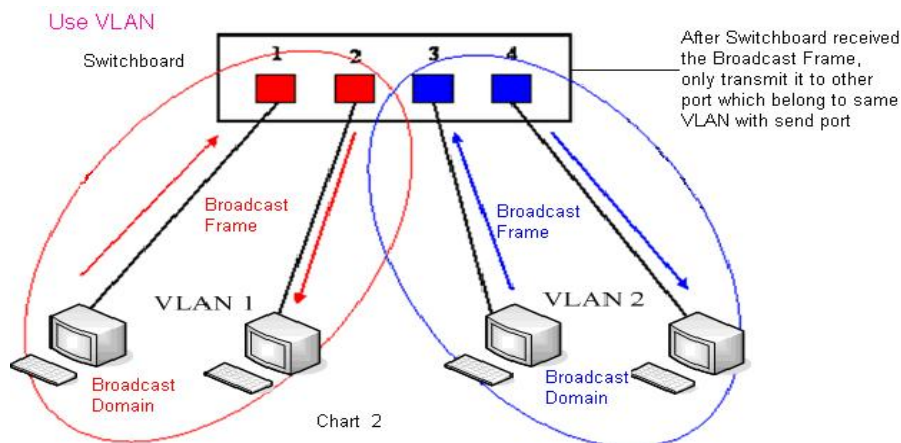
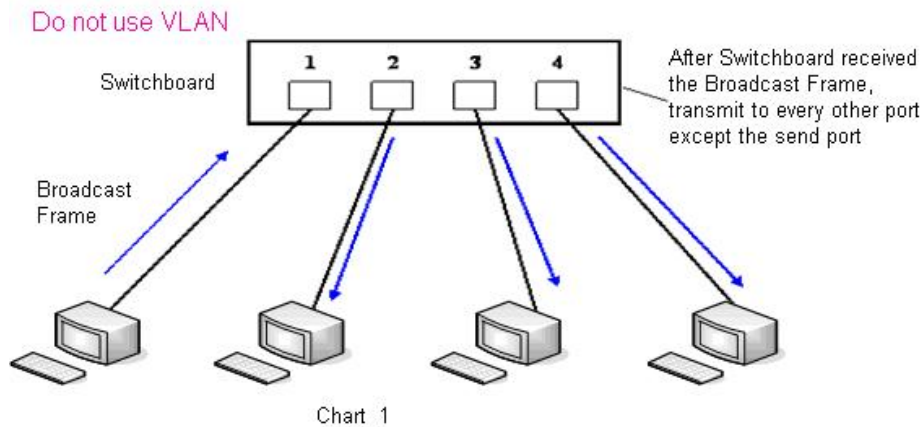

In chart 1, there is two-layer switch without setting VLAN. Any broadcast frame will be transmitted to the other ports except the send port. For example, a broadcast information is sent out from port 1 then transmitted to port 2,3and 4.

In chart 2, red and blue indicate two different VLANs in the switch, and port 1 and port 2 belong to red VLAN, port 3 and port 4 belong to blue VLAN. If a broadcast frame is sent out from port 1, switch will transmit it to port 2, the other port in the red VLAN and not transmit it to port3 and port 4 in blue VLAN. By this means, VLAN divide the broadcast domain via restricting the range of broadcast frame transmission.

Note: chart 2 use red and blue to identify the different VLAN, but in practice, VLAN uses different VLAN IDs to identify.

NETWORK

WAN	LAN	QOS	SERVICE PORT	DHCP SERVER	NTP
QoS Set					
<input type="checkbox"/> VLAN Enable					
<input checked="" type="checkbox"/> VLAN ID Check Enable		VoIP/Other VLAN differentiated		Undifferentiated ▾	
<input type="checkbox"/> DiffServ Enable		DiffServ Value		0x b8	
VoIP Data 802.1P Priority		0 (0 - 7)		Other Data 802.1P Priority	
VoIP Data VLAN ID		256 (0 - 4095)		Other Data VLAN ID	
				254 (0 - 4095)	
<input type="button" value="APPLY"/>					

QoS Configuration

Field name	explanation
VLAN Enable	Before select it to enable VLAN, you need enable Bridge mode in LAN config.
VLAN ID Check Enable	Enable VLAN ID check by selecting it. After enable VLAN ID check, if VLAN ID of a data package is not the same with the gateway or a data package do not have VLAN ID, the data package will be discarded.
Voice/Data VLAN differentiated	After enable VLAN, system will set packets with different type of VLAN ID. Undifferentiated means after using VLAN, both VoIP packets and other data packets will use the voice VLAN ID; tag differentiated means after using VLAN, VoIP(signal and voice) packets will add voice VLAN ID, and other data packets will add data VLAN ID; data untagged means after using VLAN, only VoIP packets will add voice VLAN ID. Other data packets will not use VLAN.
DiffServ Enable	Select it or not to Enable or disable DiffServ.
DiffServ Value	Set DiffServ value, the common value is 0x00.
Voice 802.1P Priority	Specify 802.1P Priority of voice/signal data package.
Data 802.1P Priority	Set 802.1p of data VLAN. Non-VoIP data (such as http, telnet, ping etc) will use this value to set VLAN package.
Voice VLAN ID	Set VLAN ID of voice/signal data package.
Data VLAN ID	Set 802.1q of data VLAN ID. Non-VoIP data (such as http, telnet, ping etc) will use this value to set VLAN package.

Notice :

- 1) Startup VLAN, if set Voice/Data VLAN differentiated as Undifferentiated, all packets will use the Voice VLAN ID as the tag.
- 2) Startup VLAN, if set Voice/Data VLAN differentiated as tag differentiated and disables the DiffServ, then system will not distinguish the voice and data, all packets will use the Voice VLAN ID as the tag.
- 3) Startup VLAN, if set Voice/Data VLAN differentiated as tag differentiated and enables the DiffServ, then system will distinguish the voice and data and add the VLAN ID each other.

- 4) Startup VLAN, if set Voice/Data VLAN differentiated as data untagged, then the packet of the signal/voice will use the Voice VLAN ID as the tag, but the data packets will not take the VLAN tag.
- 5) If Disable the VLAN, regardless to set the Voice/Data VLAN differentiated or not, all packets will not take the VLAN tag; If enable the DiffServ, all packets will only take the DiffServ value.
- 6) One must to notice, enable the VLAN ID Check Enable that is default, If enable it, the gateway will match the VLAN ID strictly. When others' VLAN ID not matches with us, the packets will discard. Contrarily, the gateway will accept the packets with the distinct VLAN ID.
- 7) You must gain the IP with the Static mode when you set VLAN, otherwise can't gain the IP in the VLAN and also can not dial with point to point.

5.3.2.4. Service Port

You can set the port of HTTP/RTP by this page.

NETWORK	
WAN	LAN
QOS	SERVICE PORT
DHCP SERVER	NTP
Service Port	
HTTP Port	80
RTP Initial Port	10000
RTP Port Quantity	200
<input type="button" value="APPLY"/>	
If modify HTTP port,you'd better set it more than 1024,then restart.	

SERVICE PORT

Field name	explanation
HTTP Port	set web browse port, the default is 80 port, if you want to enhance system safety, you'd better change it into non-80 standard port ; Example: The IP address is 192.168.1.70. and the port value is 8090, the accessing address is http://192.168.1.70:8090
RTP Initial Port	Set the RTP Initial Port. It is dynamic allocation.
RTP Port Quantity	Set the maximum quantity of RTP Port, the default is 200.

Notice:

- 1) You need save the configuration and reboot the gateway after set this page.
- 2) If you modify the port of Telnet and HTTP, you would better set the value more than 1024 because the port value less than 1024 is system port reserved.
- 3) if you set 0 for the HTTP port, it will disable HTTP service.

5.3.2.5. DHCP SERVER

NETWORK

WAN
LAN
QOS
SERVICE PORT
DHCP SERVER
NTP

DHCP Leased Table

Leased IP Address	Client Hardware Address
192.168.10.2	00-01-0e-59-68-a2

DHCP Lease Table

Name	Start IP	End IP	Lease Time	Netmask	Gateway	DNS
lan	192.168.10.2	192.168.10.30	1440	255.255.255.0	192.168.10.1	192.168.10.1

DHCP Lease Table Setting

Lease Table Name	<input type="text"/>
Start IP	<input type="text"/>
End IP	<input type="text"/>
Lease Time	<input type="text"/> (minute)
Netmask	<input type="text"/>
Gateway	<input type="text"/>
DNS	<input type="text"/>

DHCP Lease Table Delete

Lease Table Name	lan	<input type="button" value="Delete"/>
------------------	-----	---------------------------------------

DNS relay Setting

DNS Relay	<input checked="" type="checkbox"/>	<input type="button" value="APPLY"/>
-----------	-------------------------------------	--------------------------------------

DHCP SERVER

Field name	explanation
------------	-------------

DHCP Leased Table	
Leased IP Address	Client Hardware Address
192.168.10.2	00-01-0e-59-68-a2

DHCP Leased Table IP-MAC mapping table. If the LAN port of the gateway connects to a device, this table will show the IP and MAC address of this device.

DHCP Lease Table						
Name	Start IP	End IP	Lease Time	Netmask	Gateway	DNS
lan	192.168.10.2	192.168.10.30	1440	255.255.255.0	192.168.10.1	192.168.10.1

Shows the DHCP Lease Table, the unit of Lease time is Minute.

DHCP Lease Table Setting	
Lease Table Name	<input type="text"/>
Start IP	<input type="text"/>
End IP	<input type="text"/>
Lease Time	<input type="text"/> (minute)
Netmask	<input type="text"/>
Gateway	<input type="text"/>
DNS	<input type="text"/>

Lease Table Name Specify the name of the lease table

Start IP Set the start IP address of the lease table

End IP Set the end IP address of the lease table, the network device connected to LAN port will get IP address

	between Start IP and End IP by DHCP.
Netmask	Set the Netmask of the lease table
Gateway	Set the Gateway of the lease table
Lease Time	Set the Lease Time of the lease table
DNS	Set the default DNS server IP of the lease table; Click the Add button to submit and add this lease table

DHCP Lease Table Delete	
Lease Table Name	lan <input type="button" value="Delete"/>

Select name of lease table, click the Delete button will delete the selected lease table from DHCP lease table.

DNS Relay Select DNS Relay, the default is enabled. Click the Apply button to become effective.

Notice:

- 1) The size of lease table can not be larger than the quantity of C network IP address. We recommend you to use the default lease table and not modify it.
- 2) If you modifies the DHCP lease table, you need save the configuration and reboot.

5.3.2.6. NTP

Setting time zone and NTP (Simple Network Time Protocol) server according to your location, you can also manually adjust date and time in this web page.

NETWORK	
WAN LAN QOS SERVICE PORT DHCP SERVER NTP	
NTP Time Set	
Server	209.81.9.7
Time Zone	(GMT+08:00)Beijing,Chongqing,Hong Kong,Urumqi
Time Out	60 (seconds)
NTP	<input checked="" type="checkbox"/>
<input type="button" value="APPLY"/>	

NTP

Field name	explanation
Server	Set NTP Server IP address.
Time Zone	Select the Time zone according to your location.
Time Out	Set the time out, the default is 60 seconds.
NTP	Select the NTP, and click Apply to make the NTP Times effective.

5.3.3. VOIP

5.3.3.1. SIP Config

Set your SIP server in the following interface.

VOIP

SIP | STUN | DIAL PEER

SIP Line Select

SIP 1

Basic Setting

Register Status	Unapplied	Display Name	<input type="text"/>
Server Name	<input type="text"/>	Proxy Server Address	<input type="text"/>
Server Address	<input type="text"/>	Proxy Server Port	<input type="text"/>
Server Port	5060	Proxy Username	<input type="text"/>
Account Name	<input type="text"/>	Proxy Password	<input type="text"/>
Password	<input type="text"/>	Domain Realm	<input type="text"/>
Phone Number	<input type="text"/>	Port Select	Port 1 <input type="button" value="v"/>
Enable Register	<input checked="" type="checkbox"/>		

Advanced SIP Setting

Register Expire Time	60 seconds	Forward Type	Off <input type="button" value="v"/>
NAT Keep Alive Interval	60 seconds	Forward Phone Number	<input type="text"/>
User Agent	Voip Phone 1.0	Server Type	COMMON <input type="button" value="v"/>
DTMF Mode	DTMF_RELAY <input type="button" value="v"/>	Subscribe Expire Time	300 seconds
Media Key	<input type="text"/>	RFC Protocol Edition	RFC3261 <input type="button" value="v"/>
Local Port	5060	Transport Protocol	UDP <input type="button" value="v"/>
RFC Privacy Edition	NONE <input type="button" value="v"/>	MWI Number	<input type="text"/>
Transfer Expire Time	0 seconds	Enable DNS SRV	<input type="checkbox"/>
Enable Keep Authentication	<input type="checkbox"/>	Enable Subscribe	<input type="checkbox"/>
NAT Keep Alive	<input type="checkbox"/>	Rtp Encode	<input type="checkbox"/>
Enable Via rport	<input type="checkbox"/>	Enable Session Timer	<input type="checkbox"/>
Enable PRACK	<input type="checkbox"/>	Answer With Single Codec	<input type="checkbox"/>
Long Contact	<input type="checkbox"/>	Auto TCP	<input type="checkbox"/>
Enable URI Convert	<input checked="" type="checkbox"/>	Enable Strict Proxy	<input type="checkbox"/>
Dial Without Register	<input type="checkbox"/>	Enable GRUU	<input type="checkbox"/>
Ban Anonymous Call	<input type="checkbox"/>	Enable Displayname Quote	<input type="checkbox"/>
Enable Device ID	<input type="checkbox"/>		

SIP Config

Field name	explanation
SIP Line Select	
SIP 1 <input type="button" value="Load"/>	

Choose line to set info about SIP, there are 3 lines to choose. You can switch by **[Load]** button.

- | | |
|------------------------|--|
| Register Status | Shows if the gateway has been registered the SIP server or not; or so, show Unapplied; |
| Server Name | Set the server name. |
| Server Address | Input your SIP server address. |
| Server Port | Set your SIP server port. |
| Account Name | Input your SIP register account name. |
| Password | Input your SIP register password. |
| Phone Number | Input the phone number assigned by your VoIP service provider. Phone will not register if there is no phone number configured. |
| Display Name | Set the display name. |

Proxy Server Address	Set proxy server IP address (Usually, Register SIP Server configuration is the same as Proxy SIP Server. But if your VoIP service provider give different configurations between Register SIP Server and Proxy SIP Server, you need make different settings.)
Proxy Server Port	Set your Proxy SIP server port.
Proxy Username	Input your Proxy SIP server account.
Proxy Password	Input your Proxy SIP server password.
Domain Realm	Set the sip domain if needed, otherwise this VoIP gateway will use the Register server address as sip domain automatically. (Usually it is same with registered server and proxy server IP address).
Port Select	To select port for SIP accounts (port1 corresponds FXS1, port2 corresponds FXS2).
Enable Register	Start to register or not by selecting it or not.
Register Expire Time	Set expire time of SIP server register, default is 60 seconds. If the register time of the server requested is longer or shorter than gateway configured time, the gateway will change automatically the time into the time recommended by the server, and register again.
NAT Keep Alive Interval	Set examining interval of the server, default is 60 seconds
User Agent	Set the user agent if have, the default is VoIP Phone 1.0
DTMF Mode	Select DTMF sending mode, there are three modes: <ul style="list-style-type: none"> ● DTMF_RELAY ● DTMF_RFC2833 ● DTMF_SIP_INFO Different VoIP Service providers may provide different modes.
Media Key	Set the key for RTP encryption
Local port	Set sip port of each line
RFC Privacy Edition	Set Anonymous call out safely; Support RFC3323and RFC3325;
Transfer Expire Time	For the gateway supports the transfer of certain special features server, set interval time between sending “bye” and hanging up after the phone transfers a call.
Enable Keep Authentication	Enable/Disable Keep Authentication System will take the last authentication field which is passed the authentication by server to the request packet. It will decrease the server’s repeat authorization work, if it

	is enable.
	Enable/Disable keeps NAT of SIP alive.
NAT Keep Alive	If some server refuse to register with too short interval time, and has no packets sending to device in private network to keep NAT alive, user could set this function ON. And set the interval time less than the NAT server's.
Enable Via report	Enable/Disable system to support RFC3581. Via report is special way to realize SIP NAT.
Enable PRACK	Enable or disable SIP PRACK function, suggest use the default config.
Long Contact	Set more parameters in contact field; connection with SEM server
Enable URI Convert	Convert # to %23 when send the URI.
Dial Without Register	Set call out by proxy without registration;
Ban Anonymous Call	Set to ban Anonymous Call;
	Select call forward mode, the default is Off
Forward Type	<ul style="list-style-type: none"> ● Off : Close down calling forward ● Busy : If the phone is busy, incoming calls will be forwarded to the appointed phone. ● No answer: If there is no answer, incoming calls will be forwarded to the appointed phone. ● Always : Incoming calls will be forwarded to the appoint phone directly. <p>The phone will Prompt the incoming while doing forward.</p>
Forward Phone Number	Appoint your forward phone number.
Server Type	Select the special type of server which is encrypted, or has some unique requirements or call flows.
Subscribe Expire Time	Overtime of resending subscribe packet. Suggest using the default config.
RFC Protocol Edition	Select SIP protocol version to adapt for the SIP server which uses the same version as you select. For example, if the server is CISCO5300, you need to change to RFC2543; else phone may not cancel call normally. System uses RFC3261 as default.
Transport Protocol	Set transport protocols, TCP or UDP;
MWI Number	Input the number of the server's voice-mail box
Enable DNS SRV	Support DNS looking up with _sip.udp mode
Enable subscribe	Enable the option, the gateway will receive the

	notify from the server.
RTP Encode	Enable/Disable RTP Encrypt.
Enable Session Timer	Set Enable/Disable Session Timer, whether support RFC4028.It will refresh the SIP sessions.
Answer With Single Codec	Enable/Disable the function when call is incoming, phone replies SIP message with just one codec which phone supports.
Auto TCP	Set to use automatically TCP protocol to guarantee usability of transport as message is above 1300 byte
Enable Strict Proxy	Support the special SIP server-when phone receives the packets sent from server, phone will use the source IP address, not the address in via field.
Enable GRUU	Set to support GRUU
Enable Display name Quote	Set to make quotation mark to display name as the phone sends out signal, in order to be compatible with server.

5.3.3.2. Stun Config

In this web page, you can config SIP STUN.

STUN:

By STUN server, the gateway in private network could know the type of NAT and the NAT mapping IP and port of SIP. The gateway might register itself to SIP server with global IP and port to realize the device both calling and being called in private network.

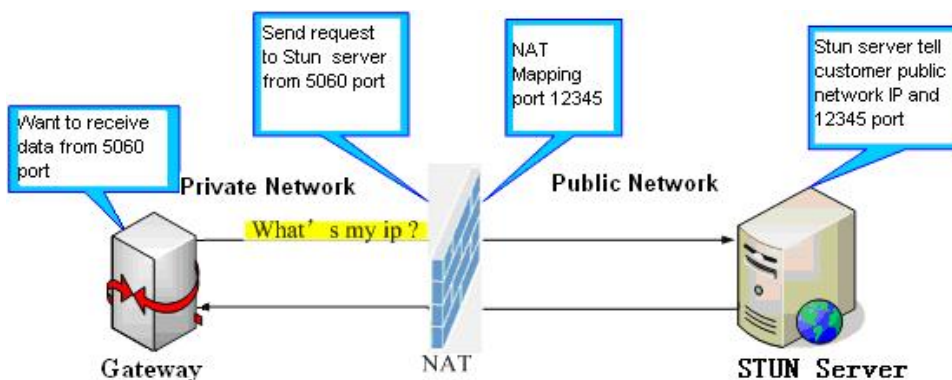

VOIP

SIP | **STUN** | DIAL PEER

STUN Set

STUN NAT Transverse	FALSE
STUN Server Addr	
STUN Server Port	3478
STUN Effect Time	50 Seconds
Local SIP Port	5060

APPLY

Set Sip Line Enable STUN

SIP 1

Use STUN

APPLY

STUN

Field name	explanation
STUN NAT Transverse	Shows STUN NAT Transverse estimation, true means STUN can penetrate NAT, while False means not.
STUN Server Addr	Set your SIP STUN Server IP address
STUN Server Port	Set your SIP STUN Server Port
STUN Effect Time	Set STUN Effective Time. If NAT server finds that a NAT mapping is idle after time out, it will release the mapping and the system need send a STUN packet to keep the mapping effective and alive.
Local SIP Port	Set the SIP port.

Set Sip Line Enable Stun

SIP 1

Choose line to set info about SIP, There are 2 lines to choose. You can switch by **[Load]** button.

Use Stun Enable/Disable SIP STUN.

Notice: SIP STUN is used to realize SIP penetration to NAT. If your phone configures STUN Server IP and Port (default is 3478), and enable SIP Stun, you can use the ordinary SIP Server to realize penetration to NAT.

5.3.3.3. DIAL PEER setting

This functionality offers you more flexible dial rules; you can refer to the following content to know how to use this dial rule. When you want to dial an IP address, the entry of IP addresses is very cumbersome, but by this functionality, you can set number 156 to replace 192.168.1.119 here.

Number	Destination	Port	Mode	Alias	Suffix	Del Length
156	192.168.1.119	5060	SIP	no alias	no suffix	0

When you want to dial a long distance call to Beijing, you need dial an area code 010 before local phone number, but you can also dial number 1 instead of 010 after we make a setting according to this dial rule. For example, you want to dial

01062213123, but you need dial only 162213123 to realize your long distance call after you make this setting.

Number	Destination	Port	Mode	Alias	Suffix	Del Length
1T	0.0.0.0	5060	SIP	rep:010	no suffix	1

To save the memory and avoid abundant input of user, add the follow functions:

Number	Destination	Port	Mode	Alias	Suffix	Del Length
13xxxxxxxx	0.0.0.0	5060	SIP	add:0	no suffix	0
13[5-9]xxxxxxxx	0.0.0.0	5060	SIP	add:0	no suffix	0

1、x Match any single digit that is dialed.

If user makes the above configuration, after user dials 11 digit numbers started with 13, the phone will send out 0 plus the dialed numbers automatically.

2、[] Specifies a range that will match digit. It may be a range, a list of ranges separated by commas, or a list of digits.

If user makes the above configuration, after user dials 11 digit numbers started with from 135 to 139, the phone will send out 0 plus the dialed numbers automatically.

Use this phone you can realize dialing out via different lines without switch in web interface.

VOIP

SIP
IAX2
STUN
DIAL PEER

Dial Peer Table

Number	Destination	Port	Mode	Alias	Suffix	Del Length
156	192.168.1.119	5060	SIP	no alias	no suffix	0
1T	0.0.0.0	5060	SIP	rep:010	no suffix	1
13xxxxxxxx	0.0.0.0	5060	SIP	add:0	no suffix	0
13[5-9]xxxxxxxx	0.0.0.0	5060	SIP	add:0	no suffix	0

Add Dial Peer

Phone Number	<input type="text"/>
Destination (optional)	<input type="text"/>
Port(optional)	<input type="text"/>
Alias(optional)	<input type="text"/>
Call Mode	SIP <input type="button" value="v"/>
Suffix(optional)	<input type="text"/>
Delete Length (optional)	<input type="text"/>

Dial Peer Option

<input type="text" value="156"/> <input type="button" value="v"/>	<input type="button" value="Delete"/> <input type="button" value="Modify"/>
---	---

DIAL PEER

Field name	explanation
------------	-------------

Phone number

There are two types of matching conditions: one is full matching, the other is prefix matching. In the Full matching, you need input your desired phone number in this blank, and then you need dial the phone number to realize calling to what the phone number is mapped. In the prefix matching, you need input your desired prefix number and T; then dial the prefix and a

phone number to realize calling to what your prefix number is mapped. The prefix number supports at most 30 digits

- Destination** Set Destination address. This is optional config item. If you want to set peer to peer call, please input destination IP address or domain name. If you want to use this dial rule on SIP2 line, you need input 255.255.255.255 or 0.0.0.2 in it.SIP3 into 0.0.0.3
- Port** Set the Signal port, the default is 5060 for SIP.
- Alias** Set alias. This is optional config item. If you don't set Alias, it will show no alias.

Note: There are four types of aliases.

- 1) add: xxx, it means that you need dial xxx in front of phone number, which will reduce dialing number length.
- 2) all: xxx, it means that xxx will replace some phone number.
- 3) del: It means that phone will delete the number with length appointed.
- 4) Rep: It means that phone will replace the number with length and number appointed.

You can refer to the following examples of different alias application to know more how to use different aliases and this dial rule.

- Call Mode** Select different signal protocol, SIP
- Suffix** Set suffix, this is optional config item. It will show no suffix if you don't set it.
- Delete Length** Set delete length. This is optional config item. For example: if the delete length is 3, the phone will delete the first 3 digits then send out the rest digits. You can refer to examples of different alias application to know how to set delete length.

Examples of different alias application

Set by web	explanation	example														
<table border="1" style="width: 100%; border-collapse: collapse;"> <tr><td>Phone Number</td><td>9T</td></tr> <tr><td>Destination (optional)</td><td>255.255.255.255</td></tr> <tr><td>Port(optional)</td><td></td></tr> <tr><td>Alias(optional)</td><td>del</td></tr> <tr><td>Call Mode</td><td>SIP <input type="button" value="v"/></td></tr> <tr><td>Suffix(optional)</td><td></td></tr> <tr><td>Delete Length (optional)</td><td>1</td></tr> </table>	Phone Number	9T	Destination (optional)	255.255.255.255	Port(optional)		Alias(optional)	del	Call Mode	SIP <input type="button" value="v"/>	Suffix(optional)		Delete Length (optional)	1	<p>You need set phone number, Destination, Alias and Delete Length.</p> <p>Phone number is XXXT; Destination is 255.255.255.255 (0.0.0.2) and Alias is del.</p> <p>This means any phone No. that starts with your set phone number will be sent via SIP2 line after the first several digits of your dialed</p>	<p>If you dial "93333", the SIP2 server will receive "3333"</p>
Phone Number	9T															
Destination (optional)	255.255.255.255															
Port(optional)																
Alias(optional)	del															
Call Mode	SIP <input type="button" value="v"/>															
Suffix(optional)																
Delete Length (optional)	1															

	<p>phone number are deleted according to delete length.</p>															
<table border="1"> <tr><td>Phone Number</td><td>2</td></tr> <tr><td>Destination (optional)</td><td></td></tr> <tr><td>Port(optional)</td><td></td></tr> <tr><td>Alias(optional)</td><td>all:33334444</td></tr> <tr><td>Call Mode</td><td>SIP</td></tr> <tr><td>Suffix(optional)</td><td></td></tr> <tr><td>Delete Length (optional)</td><td></td></tr> </table>	Phone Number	2	Destination (optional)		Port(optional)		Alias(optional)	all:33334444	Call Mode	SIP	Suffix(optional)		Delete Length (optional)		<p>This setting will realize speed dial function, after you dialing the numeric key “2”, the number after all will be sent out.</p>	<p>When you dial “2”, the SIP1 server will receive 33334444</p>
Phone Number	2															
Destination (optional)																
Port(optional)																
Alias(optional)	all:33334444															
Call Mode	SIP															
Suffix(optional)																
Delete Length (optional)																
<table border="1"> <tr><td>Phone Number</td><td>8T</td></tr> <tr><td>Destination (optional)</td><td></td></tr> <tr><td>Port(optional)</td><td></td></tr> <tr><td>Alias(optional)</td><td>add:0755</td></tr> <tr><td>Call Mode</td><td>SIP</td></tr> <tr><td>Suffix(optional)</td><td></td></tr> <tr><td>Delete Length (optional)</td><td></td></tr> </table>	Phone Number	8T	Destination (optional)		Port(optional)		Alias(optional)	add:0755	Call Mode	SIP	Suffix(optional)		Delete Length (optional)		<p>The phone will automatically send out alias number adding your dialed number, if your dialed number starts with your set phone number.</p>	<p>When you dial “8309“, the SIP1 server will receive “07558309”</p>
Phone Number	8T															
Destination (optional)																
Port(optional)																
Alias(optional)	add:0755															
Call Mode	SIP															
Suffix(optional)																
Delete Length (optional)																
<table border="1"> <tr><td>Phone Number</td><td>010T</td></tr> <tr><td>Destination (optional)</td><td></td></tr> <tr><td>Port(optional)</td><td></td></tr> <tr><td>Alias(optional)</td><td>rep:0086</td></tr> <tr><td>Call Mode</td><td>SIP</td></tr> <tr><td>Suffix(optional)</td><td></td></tr> <tr><td>Delete Length (optional)</td><td>3</td></tr> </table>	Phone Number	010T	Destination (optional)		Port(optional)		Alias(optional)	rep:0086	Call Mode	SIP	Suffix(optional)		Delete Length (optional)	3	<p>You need set Phone Number, Alias and Delete Length. Phone number is XXXT and Alias is rep:xxx If your dialed phone number starts with your set phone number, the first digits same as your set phone number will be replaced by the alias number specified and New phone number will be send out.</p>	<p>When you dial “0106228”, the SIP1 server will receive “86106228”</p>
Phone Number	010T															
Destination (optional)																
Port(optional)																
Alias(optional)	rep:0086															
Call Mode	SIP															
Suffix(optional)																
Delete Length (optional)	3															

<table border="1"> <tr><td>Phone Number</td><td>147</td></tr> <tr><td>Destination (optional)</td><td></td></tr> <tr><td>Port(optional)</td><td></td></tr> <tr><td>Alias(optional)</td><td></td></tr> <tr><td>Call Mode</td><td>SIP</td></tr> <tr><td>Suffix(optional)</td><td>0011</td></tr> <tr><td>Delete Length (optional)</td><td></td></tr> </table>	Phone Number	147	Destination (optional)		Port(optional)		Alias(optional)		Call Mode	SIP	Suffix(optional)	0011	Delete Length (optional)		<p>If your dialed phone number starts with your set phone number. The phone will send out your dialed phone number adding suffix number.</p>	<p>When you dial "147", the SIP1 server will receive "1470011"</p>
Phone Number	147															
Destination (optional)																
Port(optional)																
Alias(optional)																
Call Mode	SIP															
Suffix(optional)	0011															
Delete Length (optional)																

5.3.4. Phone

5.3.4.1. DSP Config

In this page, you can configure voice codec, input/output volume and so on.

PHONE

DSP
CALL SERVICE
DIGITAL MAP

Port Select

Port 1
Load

DSP Port Configuration

First Codec	g711Ulaw6	Second Codec	g711Alaw6
Third Codec	g729	Fourth Codec	g726-32
CallerID Tx Mode	DTMF	Fax Mode	T.38
Output Volume	0 (0-5)	Port Phone Number	

APPLY

DSP Global Configuration

G729 Payload Length	20ms	Signal Standard	China
Flashhook Min Time	200 (>=50ms)	Flashhook Max Time	800 (<=1000ms)
Dtmf Payload Type	101 (96-127)	VAD	<input type="checkbox"/>

APPLY

DSP Configuration

Field name	explanation
Port Select	Select port for setting
First Codec	The first preferential DSP codec: G.711A/u, G.726-32, G.729
Second Codec	The second preferential DSP codec: G.711A/u, G.726-32, G.729
Third Codec	The third preferential DSP codec: G.711A/u, G.726-32, G.729
Forth Codec	The forth preferential DSP codec: G.711A/u, G.726-32, G.729
CallerID Tx Mode	Set the standard only supports sending DTMF CallerID of the PSTN phone.
Fax Mode	Set fax mode.
Output Volume	Specify Output (receiver) Volume grade.
G729 Payload Length	Set G729 Payload Length

Signal Standard	Select Signal Standard.
Flashhook Min Time	Set the minimum time detection of inserted spring.
Flashhook Max Time	Set the maximum time inserted spring.
DTMF Payload Type	DTMF effective load
VAD	Select it or not to enable or disable VAD. If enable VAD, G729 Payload length could not be set over 20ms.

Notice: In the use of gateway for fax, avoid two fax devices in the same room

5.3.4.2. Call Service

In this web page, you can configure Hotline, Call Transfer, Call Waiting, 3 Ways Call, Black List, and Limit List and so on.

PHONE

DSP
CALL SERVICE
DIGITAL MAP

Port Select

Port 1 ▾
Load

Call Service Setting

Hot Line	<input type="text"/>	Warm Line Time	0 (0~9 seconds)
P2P IP Prefix	.	No Answer Time	20 (0~60 seconds)
Do Not Disturb	<input type="checkbox"/>	Accept Any Call	<input checked="" type="checkbox"/>
Enable Call Transfer	<input checked="" type="checkbox"/>	Ban Outgoing	<input type="checkbox"/>
Enable Three Way Call	<input checked="" type="checkbox"/>	Enable Call Waiting	<input checked="" type="checkbox"/>

APPLY

Black List

Black List

Add
▾
Delete

Limit List

Limit List

4163

Add
416: ▾
Delete

Call Service

Field name	explanation
Port Select	Select port for setting.
Hotline	Specify Hotline number. If you set the number, you can not dial any other numbers.
Warm line time	Automatically after configuration hooks time to call the hotline number. If configured to 0, the hook immediately after the call the hotline number
P2P IP Prefix	Set Prefix in peer to peer IP call. For example: what you want to dial is 192.168.1.119, If you define P2P IP Prefix as 192.168.1., you dial only #119 to reach 192.168.1.119. Default is “.”. If there is no “.” Set, it means to disable dialing IP.

No Answer Time	Specify No Answer Time			
Do Not Disturb	Select NO Disturb, the phone will reject any incoming call, the callers will be reminded by busy, but any outgoing call from the phone will work well.			
Accept Any Call	If select it, the phone will accept the call even if the called number is not belong to the phone.			
Enable Call Transfer	Enable Call Transfer by selecting it.			
Ban Outgoing	If you select Ban Outgoing to enable it, and you can not dial out any number.			
Enable Three Way Call	Enable Three Way Call			
Enable Call Waiting	Enable Call Waiting by selecting it.			
Black List	<p>Set Add/Delete Black list. If user does not want to answer some phone calls, add these phone numbers to the Black List, and these calls will be rejected.</p> <p>x and. Are wildcard. x means matching any single digit. for example, 4xxx expresses any number with prefix 4 which length is 4 will be forbidden to dialed out</p> <p>DOT (.) means matching any arbitrary number digit. For example, 6. expresses any number with prefix 6 will be forbidden to dial out.</p> <p>If user wants to allow a number or a series of number incoming, he may add the number(s) to the list as the white list rule. the configuration rule is -number, for example, -123456, or -1234xx</p> <table border="1" style="width: 100%; border-collapse: collapse; text-align: center;"> <tr> <td style="padding: 2px;">Black List</td> </tr> <tr> <td style="padding: 2px;">-4119</td> </tr> <tr> <td style="padding: 2px;">.</td> </tr> </table> <p>Means any incoming number is forbidden except for 4119 Note: End with DOT (.) when set up the white list</p>	Black List	-4119	.
Black List				
-4119				
.				
Limit List	<p>Set Add/Delete Limit List. Please input the prefix of those phone numbers which you forbid the phone to dial out. For example, if you want to forbid those phones of 001 as prefix to be dialed out, you need input 001 in the blank of limit list, and then you can not dial out any phone number whose prefix is 001.</p> <p>X and. Are wildcard. X means matching any single digit. for example, 4xxx expresses any number with prefix 4 which length is 4 will be forbidden to dialed out</p> <p>. Means matching any arbitrary number digit. For example, 6. expresses any number with prefix 6 will be forbidden to dial out.</p>			

Notice: Black List and Limit List can record at most 10 items respectively.

5.3.4.3. Digital Map Configuration

This system supports 4 dial modes:

- 1). End with "#": dial your desired number, and then press #.
- 2). Fixed Length: the phone will intersect the number according to your specified length.
- 3). Time Out: After you stop dialing and waiting time out, system will send the number collected.
- 4). User defined: you can customize digital map rules to make dialing more flexible. It is realized by defining the prefix of phone number and number length of dialing. In order to keep some users' secondary dialing manner when dialing the external line with PBX, phone can be added a special rule to realize it. So user can dial a number as external line prefix and get the secondary dial tone to keep dial the external number. After finishing dialing, phone will send the prefix and external number totally to the server.

For example, there is a rule 9, xxxxxxxx in the digital map table. After dialing 9, phone will send the secondary dial tone, user may keep going dialing. After finished, phone will call the number which starts with 9; actually the number sent out is 9-digit with 9.

Digital Map Configuration

Field name	explanation
End with "#"	Set Enable/Disable the phone ended with “#” dial.
Fixed Length	Specify the Fixed Length of phone ending with.
Time out	Set the timeout of the last dial digit. The call will be sent after timeout.

Below is user-defined digital map rule:

[] Specifies a range that will match digit. May be a range, a list of ranges separated by commas, or a list of digits.

x Match any single digit that is dialed.

. Match any arbitrary number of digits including none.

Tn Indicates an additional time out period before digits are sent of n seconds

in length. n is mandatory and can have a value of 0 to 9 seconds. Tn must be the last 2 characters of a dial plan. If Tn is not specified it is assumed to be T0 by default on all dial plans.

RULE
"[1-8]xxx"
"9xxxxxxx"
"911"
"99T4"
"9911x.T4"

Cause extensions 1000-8999 to be dialed immediately

Cause 8 digit numbers started with 9 to be dialed immediately

Cause 911 to be dialed immediately after it is entered.

Cause 99 to be dialed after 4 seconds.

Cause any number started with 9911 to be dialed 4 seconds after dialing ceases.

Notice: End with "#", Fixed Length, Time out and Digital Map Table can be used simultaneously, System will stop dialing and send number according to your set rules.

5.3.5. Maintenance

5.3.5.1. Auto Provision

MAINTENANCE

AUTO PROVISION	SYSLOG	CONFIG	UPDATE	ACCOUNT	REBOOT
Auto Update Setting					
Current Config Version	2.0002				
Server Address	<input type="text" value="0.0.0.0"/>				
Username	<input type="text" value="user"/>				
Password	<input type="password" value="****"/>				
Config File Name	<input type="text"/>				
Config Encrypt Key	<input type="text"/>				
Protocol Type	FTP ▾				
Update Interval Time	1 <input type="text" value=""/> Hour				
Update Mode	Disable ▾				
<input type="button" value="APPLY"/>					

Auto Provision

Field name	explanation
Current Config Version	Show the current config file's version.
Server Address	Set FTP/TFTP/HTTP server IP address for auto update. The address can be IP address or Domain name with subdirectory.
Username	Set FTP server Username. System will use anonymous if username keep blank.
Password	Set FTP server Password.
Config File Name	Set configuration file's name which need to update.

	System will use MAC as config file name if config file name keep blank. For example, 000102030405.
Config Encrypt Key	Input the Encrypt Key, if the configuration file is encrypted.
Protocol Type	Select the Protocol type FTP、TFTP or HTTP.
Update Interval Time	Set update interval time, unit is hour.
	Different update modes:
	1. Disable: means no update
Update Mode	2. Update after reboot: means update after reboot.
	3. Update at time interval: means periodic update.

5.3.5.2. Syslog Config

Syslog is a protocol which is used to record the log messages with client/server mechanism. Syslog server receives the messages from clients, and classifies them based on priority and type. Then these messages will be written into log by some rules which administrator can configure. This is a better way for log management.

8 levels in debug information:

Level 0---emergency: This is highest default debug info level. Your system can not work.

Level 1---alert: Your system has deadly problem.

Level 2---critical: Your system has serious problem.

Level 3---error: The error will affect your system working.

Level 4---warning: There are some potential dangers. But your system can work.

Level 5---notice: Your system works well in special condition, but you need to check its working environment and parameter.

Level 6---info: the daily debugging info.

Level 7---debug: the lowest debug info. Mainly be used to output debugging information.

At present, the lowest level of debug information send to Syslog is info; debug level only can be displayed on telnet.

MAINTENANCE

AUTO PROVISION	SYSLOG	CONFIG	UPDATE	ACCOUNT	REBOOT
----------------	--------	--------	--------	---------	--------

Syslog Set

Server IP	0.0.0.0
Server Port	514
MGR Log Level	None v
SIP Log Level	None v
IAX2 Log Level	None v
Enable Syslog	<input type="checkbox"/>

Syslog Configuration

Field name	explanation
Server IP	Set Syslog server IP address.

Server Port	Set Syslog server port.
MGR Log Level	Set the level of MGR log.
SIP Log Level	Set the level of SIP log.
Enable Syslog	Select it or not to enable or disable syslog.

5.3.5.3. Config Setting

MAINTENANCE

AUTO PROVISION SYSLOG CONFIG UPDATE ACCOUNT REBOOT
Save Configuration
Press the "Save" button to save the configuration files !
<input type="button" value="Save"/>
Backup Config
Save all Network and VoIP settings. Right Click here to Save as Config File (.txt)
Clear Configuration
Press the "Clear" button to Clear the configuration files !
<input type="button" value="Clear"/>

Config Setting

Field name	explanation
Save Config	You can save all changes of configurations. Click the Save button, all changes of configuration will be saved, and be effective immediately. .
Backup Config	Right clicks on "Right click here..." and select "Save Target As...." then you will save the config file in .txt format
Clear Config	User can restore factory default configuration and reboot the gateway. If you login as Admin, the gateway will reset all configurations and restore factory default; if you login as Guest, the gateway will reset all configurations except for VoIP accounts (SIP1-2 and IAX2) and version number.

5.3.5.4. Update

You can update your configuration with your config file in this web page.

MAINTENANCE

AUTO PROVISION	SYSLOG	CONFIG	UPDATE	ACCOUNT	REBOOT
Web Update					
Select file <input style="width: 150px;" type="text"/> <input type="button" value="浏览..."/> (*.*.z,*.txt,*.mmiset) <input type="button" value="Update"/>					
FTP Update					
Server	<input style="width: 95%;" type="text"/>				
Username	<input style="width: 95%;" type="text"/>				
Password	<input style="width: 95%;" type="text"/>				
File Name	<input style="width: 95%;" type="text"/>				
Type	Application update ▾				
Protocol	FTP ▾				
<input type="button" value="APPLY"/>					

Update

Field name	explanation
Web Update	Click the browse button, find out the config file saved before or provided by manufacturer, download it to the gateway directly, press “Update” to save. You can also update downloaded update file, logo picture, ring, mmiset file by web.
Server	Set the FTP/TFTP server address for download/upload. The address can be IP address or Domain name with subdirectory.
Username	Set the FTP server Username for download/upload.
Password	Set the FTP server password for download/upload.
File name	Set the name of update file or config file. The default name is the MAC of the gateway, such as 000102030405.

Notice: You can modify the exported config file. And you can also download config file which includes several modules that need to be imported. For example, you can download a config file just keep with SIP module. After reboot, other modules of system still use previous setting and are not lost.

Action type that system want to execute :

- | | |
|----------|---|
| Type | <ol style="list-style-type: none"> 1. Application update: download system update file 2. Config file export: Upload the config file to FTP/TFTP server, name and save it. 3. Config file import: Download the config file to gateway from FTP/TFTP server. The configuration will be effective after the gateway is reset. |
| Protocol | Select FTP/TFTP server |

5.3.5.5. Account Config

You can add or delete user account, and change the authority of each user account in this web page:

MAINTENANCE

[AUTO PROVISION](#) | [SYSLOG](#) | [CONFIG](#) | [UPDATE](#) | [ACCOUNT](#) | [REBOOT](#)

User Set

User Name	User Level
admin	Root
guest	General

Add User

User Name	<input type="text"/>
User Level	Root ▾
Password	<input type="password"/>
Confirm	<input type="password"/>
<input type="button" value="Submit"/>	

Account Option

admin ▾	<input type="button" value="Delete"/> <input type="button" value="Modify"/>
---------	---

Account Configuration

Field name	explanation
User Name	User Level
admin	Root
guest	General

This table shows the current user existed.

- User Name** Set account user name.
- User Level** Set user level, Root user has the right to modify configuration, General can only read.
- Password** Set the password.
- Confirm** Confirm the password.

Select the account and click the **Modify** to modify the selected account, and click the **Delete** to delete the selected account. It can add up to 5 users.

General user only can add the user whose level is General.

5.3.5.6. Reboot

MAINTENANCE

[AUTO PROVISION](#) | [SYSLOG](#) | [CONFIG](#) | [UPDATE](#) | [ACCOUNT](#) | [REBOOT](#)

Reboot Phone

Press the "Reboot" button to reboot Phone !

If you modified some configurations which need the gateway's reboot to be effective, you need click the **Reboot**, then the gateway will reboot immediately. **Notice:** Before reboot, you need confirm that you have saved all configurations.

5.3.6. Security

5.3.6.1. MMI Filter

SECURITY

MMI FILTER | FIREWALL | NAT | VPN

MMI Filter Table

Start IP	End IP	Option

MMI Filter Table Set

Start IP	End IP	
		<input type="button" value="Add"/>

MMI Filter Table Set

MMI Filter

MMI Filter

User could make some device own IP, which is pre-specified, access to the MMI of the gateway to config and manage the gateway.

Field name	explanation
------------	-------------

MMI Filter Table

Start IP	End IP	Option
192.168.1.15	192.168.1.20	<input type="button" value="Modify"/> <input type="button" value="Delete"/>

MMI Filter IP Table list:

MMI Filter Table Set

Start IP	End IP	
		<input type="button" value="Add"/>

Add or delete the IP address segments that access to the phone.

Set initial IP address in the Start IP column, Set end IP address in the End IP column, and click Add to add this IP segment. You can also click Delete to delete the selected IP segment.

MMI Filter **Select it or not to enable or disable MMI Filter. Click Apply to make it effective.**

Notice: Do not set your visiting IP outside the MMI filter range; otherwise, you can not logon through the web.

5.3.6.2. Firewall

SECURITY									
MMI FILTER		FIREWALL		NAT		VPN			
Firewall Type									
<input type="checkbox"/> In_access Enable				<input type="checkbox"/> Out_access Enable					
<input type="button" value="APPLY"/>									
Firewall Input Rule Table									
Index	Deny/Permit	Protocol	Src Addr	Src Mask	Src Port Range	Des Addr	Des Mask	Des Port Range	
Firewall Output Rule Table									
Index	Deny/Permit	Protocol	Src Addr	Src Mask	Src Port Range	Des Addr	Des Mask	Des Port Range	
Firewall Set									
Input/Output	<input type="button" value="Input"/>	Src Addr	<input type="text"/>	Des Addr	<input type="text"/>				
Deny/Permit	<input type="button" value="Deny"/>	Src Mask	<input type="text"/>	Des Mask	<input type="text"/>			<input type="button" value="Add"/>	
Protocol Type	<input type="button" value="UDP"/>	Src Port Range	<input type="text"/> - <input type="text"/>	Des Port Range	<input type="text"/> - <input type="text"/>				
Rule Delete									
Input/Output	<input type="button" value="Input"/>	Index To Be Deleted	<input type="text"/>						<input type="button" value="Delete"/>

Firewall Configuration

In this web interface, you can set up firewall to prevent unauthorized Internet users from accessing private networks connected to the Internet (input rule), or prevent unauthorized private network devices from accessing the Internet (output rule).

Firewall supports two types of rules: input access rule and output access rule. Each type supports at most 10 items.

Through this web page, you could set up and enable/disable firewall with input/output rules. System could prevent unauthorized access, or access other networks set in rules for security. Firewall, is also called access list, is a simple implementation of a Cisco-like access list (firewall). It supports two access lists: one for filtering input packets, and the other for filtering output packets. Each kind of list could be added 10 items.

We will give you an instance for your reference.

<input type="checkbox"/> In_access Enable				<input type="checkbox"/> Out_access Enable				
Input/Output	<input type="button" value="Input"/>	Src Addr	<input type="text"/>	Des Addr	<input type="text"/>			
Deny/Permit	<input type="button" value="Deny"/>	Src Mask	<input type="text"/>	Des Mask	<input type="text"/>			<input type="button" value="Add"/>
Protocol Type	<input type="button" value="UDP"/>	Src Port Range	<input type="text"/> - <input type="text"/>	Des Port Range	<input type="text"/> - <input type="text"/>			

Field name	explanation
In access enable	Select it to Enable in_ access rule
out access enable	Select it to Enable out_ access rule
Input/Output	Specify current adding rule by selecting input rule or output rule.
Deny/Permit	Specify current adding rule by selecting Deny rule or Permit rule.
Protocol Type	Filter protocol type. You can select TCP, UDP, ICMP, or

- IP.**
- Src Addr** Set source address. It can be single IP address, network address, complete address 0.0.0.0, or network address similar to *.*.*.0
- Src Mask** Set the source address' mask. For example, 255.255.255.255 means just point to one host; 255.255.255.0 means point to a network which network ID is C type.
- Src Port Range** Set the filter Src Port range
- Des Addr** Set the destination address. It can be IP address, network address, complete address 0.0.0.0, or network address similar to *.*.*.
- Des Mask** Set the destination address' mask. For example, 255.255.255.255 means just point to one host; 255.255.255.0 means point to a network which network ID is C type.
- Des Port Range** Set the filter Des Port range
- Click the Add button if you want to add a new output rule.

Firewall Output Rule Table								
Index	Deny/Permit	Protocol	Src Addr	Src Mask	Src Port Range	Des Addr	Des Mask	Des Port Range
1	Deny	ICMP	192.168.1.25	255.255.255.255	0-20000	192.168.1.119	255.255.255.255	0-20000

Then enable out access, and click the Apply button.

So when devices execute to ping 192.168.1.118, system will deny the request to send ICMP request to 192.168.1.118 for the out access rule. But if devices ping other devices which network ID is 192.168.1.0, it will be normal.

Rule Delete			
Input/Output	Input	Index To Be Deleted	<input type="text"/>

Click the Delete button to delete the selected rule.

5.3.6.3. NAT Config

NAT is abbreviated from Net Address Translation; it's a protocol responsible for IP address translation. In other word, it is responsible for transforming IP and port of private network to public, also is the IP address mapping which we usually say.

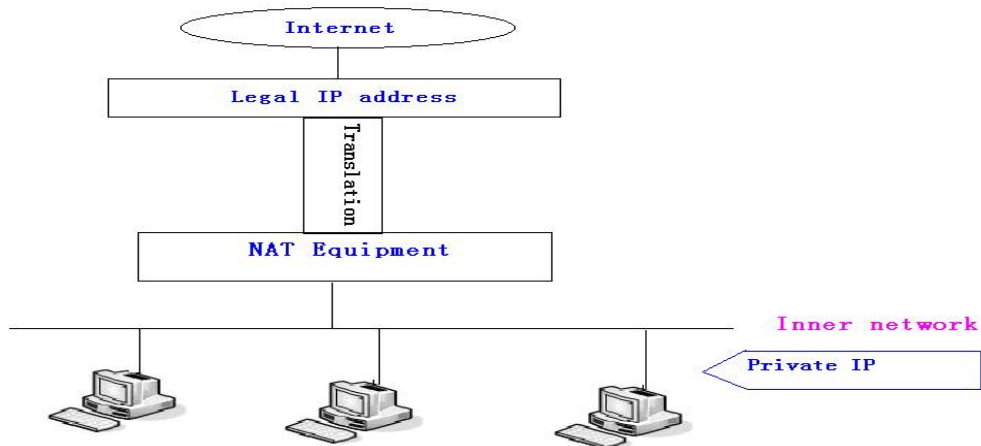

SECURITY			
MMI FILTER	FIREWALL	NAT	VPN
Protocol Set			
<input checked="" type="checkbox"/> IPsec ALG	<input checked="" type="checkbox"/> FTP ALG	<input checked="" type="checkbox"/> PPTP ALG	<input type="button" value="APPLY"/>
NAT Table			
Inside IP	Inside TCP Port	Outside TCP Port	
Inside IP	Inside UDP Port	Outside UDP Port	
NAT Table Option			
Transfer Type	TCP	Outside Port	
Inside IP		Inside Port	
<input type="button" value="Add"/>		<input type="button" value="Delete"/>	

NAT Configuration

Field name	explanation
IPsec ALG	It is an encryption technology. Select it to enable IPsec ALG, the default is enable
FTP ALG	FTP is a service of connection layer which can transform intranet IP into extranet IP when intranet IP is sending out packet. Select it to enable FTP ALG, the default is enable
PPTP ALG	Select it enable PPTP ALG, the default is enable
Inside IP	Inside TCP Port
Outside TCP Port	
Shows the NAT TCP mapping table	
Inside IP	Inside UDP Port
Outside UDP Port	
Shows the NAT UDP mapping table	
NAT Table Option	
Transfer Type	TCP
Outside Port	
Inside IP	Inside Port
<input type="button" value="Add"/>	
<input type="button" value="Delete"/>	
Transfer Type	Select the NAT mapping protocol style, TCP or UDP
Inside IP	Set the IP address of device which is connected to LAN interface to do NAT mapping.
Inside Port	Set the LAN port of the NAT mapping
Outside Port	Set the WAN port of the NAT mapping
Notice: After finish setting, click the Add button to add new mapping table;	

click the Delete button to delete the selected mapping table.

5.3.6.4. VPN Config

This web page provides us a safe connect mode by which we can make remote access to enterprise inner network from public network. That is to say, you can set it to connect public networks in different areas into inner network via a special tunnel.

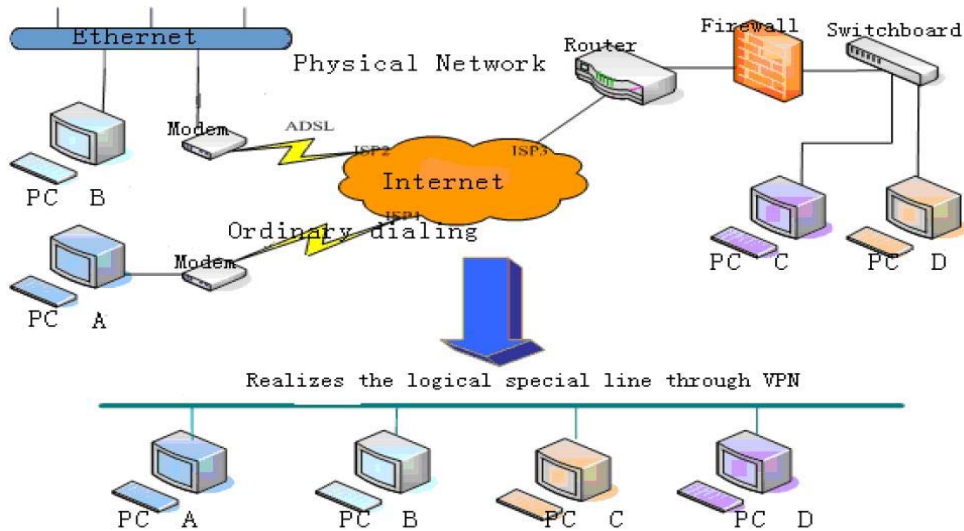

SECURITY							
MMI FILTER		FIREWALL		NAT		VPN	
VPN IP							
0.0.0.0							
VPN Mode							
<input checked="" type="radio"/> L2TP		<input type="radio"/> PPTP		<input checked="" type="checkbox"/> Enable VPN			
L2TP							
VPN Server Addr				VPN User Name			
VPN Password							
PPTP							
PPTP Server Addr				PPTP User Name			
PPTP Password							
<input type="button" value="APPLY"/>							

VPN Configuration

Field name	explanation
VPN IP	Shows the current VPN IP address
VPN Mode	
<input checked="" type="radio"/> UDP Tunnel	<input type="radio"/> L2TP
<input type="checkbox"/> Enable VPN	

Select UDP Tunnel (VPN Tunnel) or VPN L2TP. You can choose only one for current state. After you select it, you'd better save configuration and reboot your device.

Enable VPN **Select it or not to enable or disable VPN ;**

L2TP			
VPN Server Addr	<input type="text"/>	VPN User Name	<input type="text"/>
VPN Password	<input type="text"/>	<input type="text"/>	<input type="text"/>

VPN Server Addr **Set VPN L2TP Server IP address**
VPN User Name **Set User Name access to VPN L2TP Server**
VPN Password **Set Password access to VPN L2TP Server**

PPTP			
PPTP Server Addr	<input type="text"/>	PPTP User Name	<input type="text"/>
PPTP Password	<input type="text"/>	<input type="text"/>	<input type="text"/>
<input type="button" value="APPLY"/>			

VPN Server Addr **Set VPN PPTP Server IP address**
VPN User Name **Set User Name access to VPN PPTP Server**
VPN Password **Set Password access to VPN PPTP Server**

5.3.7. Logout

System Logout	
Logout	
Press the "Logout" button to Logout Phone !	
<input type="button" value="Logout"/>	

Click Logout, and you will exit web page. If you want to enter it next time, you need input user name and password again.

6. Appendix

6.1. Specification

6.1.1. Hardware

Item		A2 GATEWAY
Adapter (Input/Output)		Input: 100-240V Output: 12V 1A
port	WAN	10/100Base-T RJ-45 for LAN
	LAN	10/100Base-T RJ-45 for PC
Operation Temperature		0 ~ 40 °C
Relative Humidity		10 ~ 65%
main chip		Ralink MIPS 24KEC (320MHz)
SDRAM		16M
Flash		4M

6.1.2. Voice features

- Support SIP 2.0 (RFC3261) and correlative RFCs
- Codec: G.711A/u, G.729a/b, G.726-32k
- Echo cancellation: G.168 Compliance in LEC
- Support Voice Gain Setting, VAD, CNG
- NAT penetration, Support for STUN way through
- SIP support SIP domain, SIP authentication(none basic, MD5), DNS name of server, Peer to Peer/ IP call
- SIP can register two SIP accounts, through the Pubic Server / Private server, users can either account for inbound and outbound
- Support call line automatically selected, when the public can not connect the server when the server can automatically switch to the private call
- DTMF Relay: support SIP info, DTMF Relay, RFC2833
- SIP application: SIP Call forward/transfer (blind/attended) /hold/waiting/3 way talking/
- Call control features: Flexible dial map, hotline, empty calling No. reject service, black list for reject authenticated call, limit call, no disturb, caller ID, Flexible deer peer rule.
- Support T.38 Fax
- Add busy when N / A lines of the 4 modes
- Support FXS2 and FXS2

6.1.3. Network features

- WAN/LAN: support bridge and router model
- Support PPPoE for XDSL
- Support DHCP server in the LAN port
- Gateway ping test through keyboard commands
- Support DHCP client in the WAN port
- Support basic NAT and NAPT

- Support VLAN (optional: voice vlan/ data vlan),support NTP
- Support VPN (L2TP/PPTP) function
- WAN Port supports main DNS and secondary DNS server can select dynamically to get DNS in DHCP mode or statically set DNS address.
- QoS with DiffServ
- Support DNS relay, supports NTP Client, Firewall support the simple
- Network tools in telnet server: including ping, trace route, telnet client

6.1.4. Maintenance and management

- Support Safe Mode
- Can be updated by safe Mode
- Web ,telnet and keypad management
- Management with different account right
- Upgrade firmware through HTTP, FTP or TFTP Telnet remote management/ upload/download setting file
- Support Syslog
- Support Auto Provisioning (upgrade firmware or configuration file)

6.2. Particularly suitable for A2 two-port gateway

- Service Provider of telecom operators and (ITSP) Internet Telephony
- Large companies (for international and domestic long distance and / or internal communications, mainly in the way free sparring)
- Import and export business of small or medium enterprises, such as foreign travel, study intermediary agents, immigration agents and other intermediaries
- Foreign / joint ventures, foreign enterprises in China, offices, representatives and agents, etc.
- Foreign hotel (which can be placed in the rooms and business center or leased)
- All levels of government in dealing with foreigners more departments, such as foreign trade sector, the CPAFFC, sports units, cultural units, Foreign Experts Affairs, the foreign affairs department, etc.
- Schools and research institutes, such as the joint venture school, school or Foreign Affairs Department of the research unit.
- IP supermarkets, IP telephone booth (mostly set in the migrant workers, students focus on areas such as low-income people)
- Personal and home users, such as immigrant families, host families, student hostels, separation of individual family members due to long working relationship, often with family or friends living abroad keep in touch with the individuals.

6.3. Common Problems

Symptom	Solution
POWER light does not shine	<ol style="list-style-type: none"> 1、 Check the power connection is correct. 2、 Check the power adapter is used.
WAN/LAN link light does not shine	<ol style="list-style-type: none"> 1、 Check the cable connection is valid, check the PC card indicator light is on. 2、 Check the card is working properly, the specific approach is seen in the PC, there with "?" Or "!" Device under "Network Adapter". If so, remove the device and reinstall. Otherwise, the NIC in another slot, if not enough, replace the card.

Access modes commonly used example (already installed on your computer dial-up software)

Description:

Can not access the internet

- 1、 Make sure the front of the problem does not exist.**
- 2、 Make sure that dial-up software is properly installed and set.**
- 3、 Sure to enter the correct user name and password.**
- 4、 If it does not work after the success dial up, make sure the IE browser's proxy server is set correctly.**
- 5、 Please try to log multiple pages to confirm a Web server failure is not due.**