



# F52 VoIP Phone

## User Manual



Fanvil Technology Co., Ltd

Address: Level 3, Block A, Gaoxinqi Building, Anhua  
Industrial Park, Qianjin 1 Road, 35<sup>th</sup> District, Bao'An,  
Shenzhen, 518101 P.R. China.

Web Site: [www.fanvil.com](http://www.fanvil.com)

Tel: +86 755 26402199

Fax: +86 755 26402618



## Safety Notices

Please read the following safety notices before installing or using this phone. They are crucial for the safe and reliable operation of the device.

- Please use the external power supply that is included in the package. Other power supplies may cause damage to the phone, affect the behavior or induce noise.
- Before using the external power supply in the package, please check with home power voltage. Inaccurate power voltage may cause fire and damage.
- Please do not damage the power cord. If power cord or plug is impaired, do not use it, it may cause fire or electric shock.
- The plug-socket combination must be accessible at all times because it serves as the main disconnecting device.
- Do not drop, knock or shake it. Rough handling can break internal circuit boards.
- Do not install the device in places where there is direct sunlight. Also do not put the device on carpets or cushions. It may cause fire or breakdown.
- Avoid exposure the phone to high temperature, below 0°C or high humidity. Avoid wetting the unit with any liquid.
- Do not attempt to open it. Non-expert handling of the device could damage it. Consult your authorized dealer for help, or else it may cause fire, electric shock and breakdown.
- Do not use harsh chemicals, cleaning solvents, or strong detergents to clean it. Wipe it with a soft cloth that has been slightly dampened in a mild soap and water solution.
- When lightning, do not touch power plug or phone line, it may cause an electric shock.
- Do not install this phone in an ill-ventilated place.
- You are in a situation that could cause bodily injury. Before you work on any equipment, be aware of the hazards involved with electrical circuitry and be familiar with standard practices for preventing accidents.

# Table of Content

<b>1</b>	<b>INTRODUCING F52 VOIP PHONE .....</b>	<b>6</b>
1.1	THANK YOU FOR YOUR PURCHASING F52 .....	6
1.2	DELIVERY CONTENT.....	6
1.3	KEYPAD.....	7
1.4	PORT FOR CONNECTING .....	8
1.5	ICON INTRODUCTION .....	8
1.6	LED STATUS INTRODUCTION .....	9
<b>2</b>	<b>INITIAL CONNECTING AND SETTINGS .....</b>	<b>10</b>
2.1	CONNECT THE POWER AND NETWORK .....	10
2.1.1	Connect to network.....	10
2.1.2	Power adapter connection .....	11
2.2	BASIC INITIALIZATION.....	11
2.2.1	Network Settings .....	11
<b>3</b>	<b>THE BASIC FUNCTION OF F52 .....</b>	<b>13</b>
3.1	MAKING A CALL .....	13
3.1.1	Call Device .....	13
3.1.2	Call Methods.....	13
3.2	ANSWERING A CALL.....	14
3.3	DND.....	14
3.4	CALL FORWARD.....	14
3.5	CALL HOLD .....	14
3.6	CALL WAITING .....	15
3.7	CALL TRANSFER .....	15
3.8	THREE-WAY CONFERENCE CALL.....	15
<b>4</b>	<b>ADVANCED FUNCTION OF F52.....</b>	<b>16</b>
4.1	CLICK TO DIAL .....	16
4.2	AUTO ANSWER .....	16
4.3	HOTLINE .....	16
4.4	APPLICATION .....	16
4.4.1	SMS .....	16
4.4.2	Memo.....	17
4.4.3	Voice Mail .....	17

<b>5</b>	<b>OTHER FUNCTIONS OF F52 .....</b>	<b>18</b>
5.1	AUTO HANDDOWN.....	18
5.2	DIAL PLAN.....	18
5.3	DIAL PEER.....	18
5.4	AUTO REDIAL.....	18
5.5	CALL COMPLETION.....	18
5.6	POWER LIGHT .....	19
5.7	HIDE DTMF .....	19
5.8	PASSWORD DIAL.....	19
5.9	ACTION URL & ACTIVE URI.....	19
5.10	PUSH XML.....	20
<b>6</b>	<b>THE BASIC SETTINGS OF F52 .....</b>	<b>20</b>
6.1	KEYBOARD.....	20
6.2	SCREEN SETTINGS.....	20
6.3	RING SETTINGS .....	20
6.4	VOICE VOLUME.....	21
6.5	TIME & DATE.....	21
6.6	GREETING WORDS.....	21
6.7	LANGUAGE.....	21
<b>7</b>	<b>ADVANCED SETTINGS OF F52 .....</b>	<b>22</b>
7.1	ACCOUNTS .....	22
7.2	NETWORK .....	22
7.3	SECURITY.....	22
7.4	MAINTENANCE.....	22
7.5	FACTORY RESET .....	22
<b>8</b>	<b>WEB CONFIGURATION.....</b>	<b>23</b>
8.1	INTRODUCTION OF CONFIGURATION .....	23
8.1.1	Ways to configure .....	23
8.1.2	Password Configuration.....	23
8.2	SETTING VIA WEB BROWSER.....	23
8.3	CONFIGURATION VIA WEB .....	24
8.3.1	BASIC .....	24
8.3.2	NETWORK .....	29
8.3.3	VOIP.....	39
8.3.4	PHONE .....	55
8.3.5	FUNCTION KEY.....	70
8.3.6	Maintenance .....	71
8.3.7	SECURITY .....	79

8.3.8 LOGOUT .....	86
<b>9 APPENDIX.....</b>	<b>87</b>
9.1.1 SPECIFICATION HARDWARE .....	87
9.1.2 Voice features .....	87
9.1.3 Network features .....	88
9.1.4 Maintenance and management .....	89
■ 9.2 DIGIT-CHARACTER MAP TABLE.....	89

# 1 Introducing F52 VOIP Phone

## 1.1 Thank you for your purchasing F52

Thank you for your purchasing F52, F52 is a full-feature telephone that provides voice communication over the same data network that your computer uses. This phone's functions not only much like a traditional phone, allowing to place and receive calls, and enjoy other features that traditional phone has, but it also own many data services features which you could not expect from a traditional telephone.

This guide will help you easily use the various features and services available on your phone.

## 1.2 Delivery Content

Please check whether the delivery contains the following parts:

The base unit with display and keypad

The handset

The handset cable

The Ethernet cable

The power supply







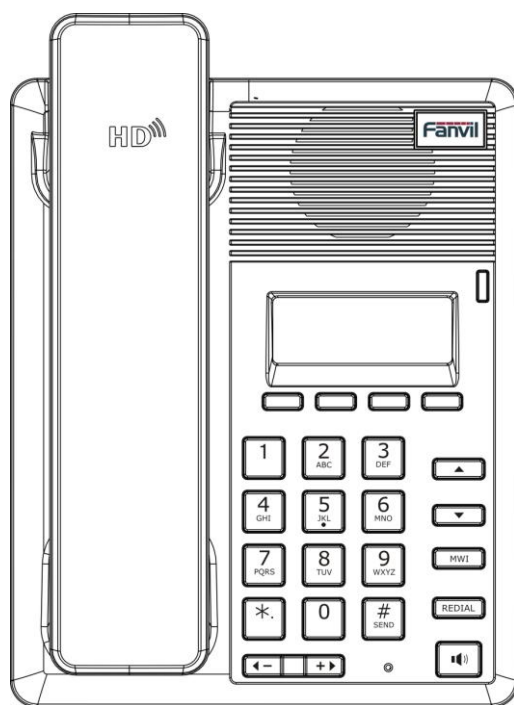

Attentions: The F52 may cause damage if you do not use a power adapter with F52. Power adapter specifications due to different areas or differentiated shipments, if the product supplied power adapter can not be used locally, please consult your local dealer.

The user manual(you may download from our website)

Here is the appearance of IP Phone description:

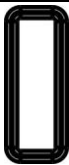

### 1.3 Keypad

Key	Key name	Function Description
 	Navigation	Navigation key assist users for operating more convinient.
	Redial	<ol style="list-style-type: none"> <li>1. In the hook off/hands-free mode, use the key to dial the last call number;</li> <li>2. In stand-by mode, it has a function to check the Outgoing Call.</li> <li>3. You could also find the specify contacts in phone book/call records, and use this number for quick dialing, press this button, you can dial quickly.</li> </ol>
	Hands-free	Make the phone into hands-free mode.
	Indicate light	This light will flash when there is a missed call
   	Soft key 1/2/3/4	Keys combination, include functions such as History/Directory/DND/Menu/Del/Redial/Send/Quit/Answer/Divert/Reject/Hold/Transfer/Co

---

nf/Close and so on.

---





Digital  
keyboard

Inputting the phone number or DTMF



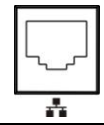

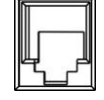

---

## 1.4 Port for connecting

Port	Name	Description
	Power switch	Input: 5V AC, 1A
	WAN	10/100M Connect it to Network
	LAN	10/100M Connect it to PC
	Headset	Port type: RJ-9 connector







---

## 1.5 Icon introduction

Icon	Description
	Call out
	Call in
	Call hold
	Auto answer
	Call mute
	Contact

---



	DND(Do not Disturb)
	In hand-free mode
	In hook mode
	SMS
	Missed call
	Call forward

## 1.6 LED Status introduction

Table 1 Power Indication LED

LED Status	Description
Steady red	Power on.
Fast Blinking red	There is an incoming call.
Off	Power off.

## 2 Initial connecting and Settings

### 2.1 Connect the power and network

#### 2.1.1 Connect to network

Please make sure your environment already have broadband internet access capability during this step.

##### 1. Broadband Router

Connect one end of the network cable to the F52's WAN port the other end is connected to your broadband router's LAN port, so that the completion of the network hardware connections. In most cases, you must configure your network settings to DHCP mode. The details setting mode please refer to 2.2.1—Network Settings.



##### 2. No broadband router

Connect one end of the network cable to the F52's WAN port, the other end is connected to your broadband modem's LAN port, so that the completion of the network hardware connections. In most cases, if you are using a TV cable broadband, you must configure your network settings to DHCP mode: if you are using ADSL, you must set your F52 to PPPOE mode. The details setting mode please refer to 2.2.1- Network Settings.

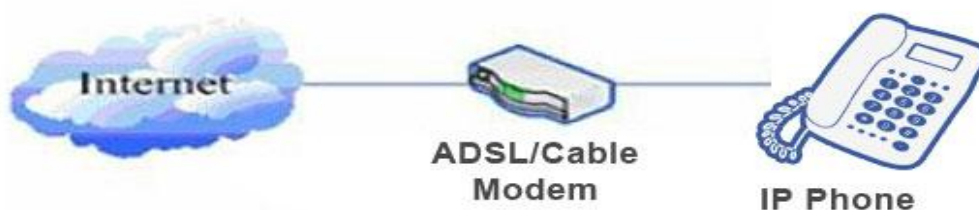

##### 3. Worked as a broadband router

F52 have broadband routing capability, as long as the F52 properly connected to the WAN port on the broadband modem and connect your computer or other Internet-capable devices connected to the F52's LAN port, then you can use the phone's ability to connect to the Internet

broadband routing. The details setting mode please refer to 2.2.1-Network Settings.



## 2.1.2 Power adapter connection

During this step, please make sure your power connector match the power outlet, meanwhile, both voltage and electric current are also comply with the work phone.

1. Plug power adapter to power socket.
2. Plug power adaptor's DC output to the DC5V port of F52 to start up.
3. There will be displayed black line and "INITIALIZING" on the screen. After finishing startup, phone will show greeting, current date and time and so forth.
4. If phone has registered to the server, you can place or answer calls

## 2.2 Basic Initialization

F52 is provided with a plenty of functions and parameters for configuration. User needs some network and VoIP knowledge so that user could understand the meanings of parameters. In order to make user use the phone more easily and convenient, there are basic configurations introduced which is mandatory to ensure phone calls.

### 2.2.1 Network Settings

During setting network of the phone please make sure that network is connected already. F52 uses DHCP to get WAN IP configurations, so phone could access to network as long as there is DHCP server in it. If there is no DHCP server available, phone has to be changed WAN network setting to Static IP or PPPoE.

#### Setting PPPoE mode(For ADSL connection)

1. Get PPPoE account and password first.
2. Press Menu->Settings->Advanced Settings, then enter passwords, and choose network ->WAN settings->Connection Mode, enter and choose PPPoE through navigation keys and press the Save key.
3. Press Back, then choose PPPoE Set, press Enter.

4. The screen will show the current information. Press Del to delete it, then input your PPPoE user and password and press Save.
5. Press Back six times to return to the idle screen.
6. Check the status. If the screen shows “**Negotiating...**” it shows that the phone is trying to access to the PPPoE Server; if it shows an IP address, then the phone has already get IP with PPPoE.

#### **Setting Static IP mode(Static ADSL/Cable, or no PPPOE/DHCP network)**

1. Prepare the network’s parameters first, such as IP Address, Net mask, Default Gateway and DNS server IP address. If you don’t know this information, please contact the service provider or technician of network.
2. Press Menu->Settings->Advanced Settings, then enter passwords, and choose network ->WAN settings->Connection Mode, enter and choose Static through navigation keys and press the Save key.
3. Press Back, then choose Static Set, press Enter.
4. The screen will show the current information, and then press Del to delete. Input your IP address, Mask, Gateway, DNS and press Save to save what you input.
5. Press Back six times to return to the idle screen.
6. Check the status, the screen shows “**Static**” .the screen shows the IP address and gateway which were set just now, if the phone could display the right time, it shows that Static IP mode takes effect.

#### **Setting DHCP mode**



1. Press Menu->Settings->Advanced Settings, then enter passwords, and choose network ->WAN settings->Connection Mode, enter and choose DHCP through navigation keys and press the Save key.
2. Press Back six times to return to the idle screen.
3. Check the status, the screen shows “**DHCP**”, If the screen shows the IP address and gateway which were set just now, it shows that DHCP mode takes effect.

## 3 The basic function of F52

### 3.1 Making a call

#### 3.1.1 Call Device

You can make a phone call via the following devices:

- 1、 Pick up the handset,  icon will be showed in the idle screen.
- 2、 Press the Speaker button,  icon will be showed in the idle screen.
- 3、 Press the headset button if the headset is connected to the Headset Port in advance. The icon  will be showed in the idle screen.

You can also dial the number first, and choose the method you will use to speak to the other party.

#### 3.1.2 Call Methods

1. Speed Dial  
In standby mode, you simply enter your number to dial and press [#] or press [Redial] to make a call
2. Hook dialing  
Pick up the handset and hear dial tone, you can start dialing. After entering the destination number, press the [#] key, F52 can immediately start connecting with each other. When you hear the beep ... beep ... long beep, the other phone started ringing, until the other party pick up the handset or use the speakerphone (time of the call is displayed on the screen), you can start talking. When the call is completed, replace the handset hang up the call.
3. Hands-free Dialing  
Press the speakerphone key and hear a dial tone, you can start dialing. After entering the destination number, press the [#] key, F52 can immediately start connecting with each other. When you hear the beep ... beep ... long beep, the other phone started ringing, until the other party pick up the handset or use the speakerphone when you can start talking. When the call is finished, press the Speakerphone key to end the call.
4. Using the Redial button  
If you try to call over the telephone, you can press [Redial] key to call a

recently dialed number one. Note that you restart the phone, the system will clear the call log, dial [Redial] key at this time will be invalid.

## 3.2 Answering a call

### Answering an incoming call:

1. If you have no other line telephone, lift the handset using, or press the Speaker button/ Answer softkey to answer using the speaker phone.
2. If you are on a call currently, press the answer softkey.

During the conversation, you can alternate between Headset and Speaker phone by pressing the corresponding buttons or picking up the handset.

## 3.3 DND

Press DND softkey to active DND Mode. Further incoming calls will be rejected and the display shows:  icon. Press DND softkey twice to deactivate DND mode. You can find the incoming call record in the Call History.

## 3.4 Call Forward

This feature allows you to forward an incoming call to another phone number. The display showed  icon.

The following call forwarding events can be configured:

**Off:** Call forwarding is deactivated by default.

**Always:** Incoming calls are immediately forwarded.

**Busy:** Incoming calls are immediately forwarded when the phone is busy.

**No Answer:** Incoming calls are forwarded when the phone is not answered after a specific period.

To configure Call Forward via Phone interface:

1. Press Menu ->Features->Enter->Call Forwarding->Enter.
2. There are 4 options: Disabled, Always, Busy, and No Answer.
3. If you choose one of them (except Disabled), enter the phone number you want to forward your call to. Press Save to save the changes.

## 3.5 Call Hold

Press the Hold button or Hold softkey to put your active call on hold. .

1. If there is only one call on hold, press the hold softkey to retrieve the call.

2. If there are more than one call on hold, press the line button, and the Up/Down button to highlight the call, then press the Unhold button to retrieve the call.

### **3.6 Call Waiting**

1. Press Menu ->Features->Enter->Call Waiting->Enter.
2. Use the navigation keys to active or inactive call waiting.
3. Then press the Save to save the changes.

### **3.7 Call Transfer**

1. Blind Transfer

During talk, press the key Transf, and then dial the number that you want to transfer to, and finished by "#". Phone will transfer the current call to the third party. After finishing transfer, the call you talk to will be hanged up. User cannot select SIP line when phone transfers call.

2. Attended Transfer

During talk, press the key Transf, then input the number that you want to transfer to and press Send. After that third party answers, then press Transfer to complete the transfer. (You need enable call waiting and call transfer first). If there are two calls, you can just talk to one, and keep hold to the other one. The one who is keep hold cannot speak to you or hear from you. In other way, if user wants to invite the third party during the call, they can press Conf to make calls mode in conference mode. If user wants to stop conference, user can press Split. (User must enable call waiting and three way call first).

Note: the server that user uses must support RFC3515 or it might not be used

3. Alert Transfer

During the talk, press Transf firstly, and then press Send after inputting the number that you want to transfer. You are waiting for connection, now, press Transf and the transfer will be done. (To use this feature, you need enable call waiting and call transfer first).

### **3.8 Three-Way conference call**

1. Press the Conf softkey during an active call.
2. The first call is placed on hold. Then you will hear a dial tone. Dial the number to conference in, then press Send key.
3. When the call is answered, press Conf and add the first call to the conference.
4. If you want to release the conference, press Split key.

## **4 Advanced function of F52**

### **4.1 Click to dial**

When user A browses in an appointed Web page, user A can click to call user B via a link (this link to user B), then user A's phone will ring, after A hooks off, the phone will dial to B.

**Notice:** It needs a external software what supports click to dial.

### **4.2 Auto answer**

When there is an incoming call, after no answer time, the phone will answer the call automatically.

### **4.3 Hotline**

You can set hotline number for every sip, and then enter the dialer interface and after Warm Line Time, the phone will call out the hotline number automatically.

### **4.4 Application**

#### **4.4.1 SMS**

- 1) Press Menu ->Applications->Enter->SMS->Enter.
- 2) Use the navigation keys to highlight the options. You can read the message in the Inbox/Outbox.
- 3) After view the new message, you can press Reply to reply the message, and use the 2aB softkey to change the Input Method, when enter the reply message, press OK, then use the navigation keys to select the line from which you want to send, then Send.
- 4) If you want to write a message, you can press New and enter message. Use the 2aB softkey to change the Input Method. When you input the message you want to send, press OK, then use the navigation keys to select the line from which you want to send, then Send.
- 5) If you want to delete the message, after view the message, press Del, then you have three options to choose: Yes, All, No.



## 4.4.2 Memo

You can add some memos to record some important things to remind you. Press Menu->Application->Memo->Enter->Add.

There are some options to configure: Mode, Date, Time, text, Ring. When the configuration is completed, press Save.

## 4.4.3 Voice Mail

- 1) Press Menu->Application->Voice Mail->Enter.
- 2) Use the navigation keys to highlight the line for which you want to set, press Edit, and use the navigation key to turn on the mode, and the input the number. Press 2aB softkey to choose the proper input method.
- 3) Press Save to save the change.
- 4) To view the new voicemail, Press the Voicemail softkey directly. Press Dial, then you may be prompted to enter the password, then you can listen to your new and old messages.

## **5 Other functions of F52**

### **5.1 Auto Handdown**

1. Press Menu ->Features-> Enter->Auto Handdown-> Enter.
2. Set the Mode Enable through the navigation key, then set Time, unit is minute, then press Save.
3. When the call ends, after the time that you have set, the phone will back to the idle interface.

### **5.2 Dial Plan**

1. Press Menu ->Features-> Enter->Dial Plan-> Enter.
2. The following plans you can set: Press # to Send, Timeout to Send, Timeout, Fixed Length Number, Press # to Do BXFER, BXFER On Onhook, AXFER On Onhook. You can enable or disable each dial plan.

### **5.3 Dial Peer**

1. Press Menu ->Features-> Enter->Dial Peer-> Enter.
2. Press Add to enter the Edit interface, and then input number and destination. For example: Number:1, Destination:1234, Then press Save.
3. Input 1# number in the dial interface, you can dial out 1234.

### **5.4 Auto Redial**

1. Press Menu ->Features-> Enter->Auto Redial-> Enter.
2. Choose Mode Enabled or Disabled through the navigation key. If you choose Enable, you also need to set Interval and Times, and then press Save.
3. After enable auto redial, calling out someone, if he is in busy, it will pop up a prompt box whether to auto redial, press OK, the phone will call out him according the Interval and Times that you set.

### **5.5 Call completion**

1. Press Menu ->Features-> Enter->Call Completion-> Enter.

2. Enable the function through the navigation key, and then Save.
3. Call out others, if he is in busy, it will pop up a prompt Call Completion Waiting number? Press OK, when he is in idle, it will pop up a prompt Call Completion Call number? Press OK, the phone will call out the number automatically.

## **5.6 Power Light**

1. Press Menu ->Features-> Enter->Power Light-> Enter.
2. Enable this function through the navigation key.

## **5.7 Hide DTMF**

1. Press Menu ->Features-> Enter->Hide DTMF-> Enter.
2. Through the navigation key to choose: Disabled, All, Delay, Last Show. When you set up a call with others and need to input the DTMF, the DTMF will show as you have set.

## **5.8 Password Dial**

1. Press Menu ->Features-> Enter->Password Dial-> Enter.
2. Enable this function , you can also set Prefix and Length. For example, you want call out 1234567 and you set Password Dial Prefix 123 and Password Length 3, then enter the dial interface and input 1234567, and then the screen will show 123\*\*\*7.

## **5.9 Action URL & Active URI**

1. Action URL, achieve results com from a functional understanding that end a phone Action produce a URL, Action which means the side of the phone receive incoming(Incoming call), outgoing calls(Outgoing call), turn DND(open DND), hang up the phone(On hook), etc. To set the phone web page lists all its support of the action, each action corresponds to a user-defined URL. When generating an action the phone is issued for the URL HTTP Get, so as to achieve the purpose of reporting their actions.

2. Active URI, achieve results come from a functional understanding that the remote(eg PC) to send a URL to the phone, the phone received will produce an action, such as dial , DND and so on. Enter the phone web pages PHONE->FEATURE, enter the Active URL limit IP(such as a PC IP) Push XML

Enter the web page of the phone->PHONE->FEATURE, input Push XML Server(e.g. PC'IP), then PC can push text, SMS, phonebook, advertisement,, execute etc. to phone to update the message or the phone makes an action.

## **5.10 Push XML**

Enter the web page of the phone->PHONE->FEATURE, input Push XML Server(e.g. PC'IP), then PC can push text, SMS, phonebook, advertisement,, execute etc. to phone to update the message or the phone makes an action.

# **6 The Basic Settings of F52**

## **6.1 Keyboard**

1. Press Menu ->Settings-> Enter->Basic Settings-> Enter->Keyboard->Enter.
2. There are four items: DSS Key settings, Programmable Keys, Desktop Long Pressed, Soft Key , You can set up respectively on them. Press the key Enter to the interface, then use the navigation keys to choose the function for the key according to you want.
3. Press the key OK to save.

## **6.2 Screen Settings**

1. Press Menu ->Settings-> Enter->Basic Settings-> Enter->Screen Settings->Enter.
2. You can set Contrast, Contrast Calibration and Backlight, press Enter and use the navigation keys to set, then press the key Save.

## **6.3 Ring Settings**

1. Press Menu ->Settings-> Enter->Basic Settings-> Enter->Ring Settings->Enter.
2. You can set Ring Volume and Ring Type, press Enter and use the navigation keys to set, then press the key Save. In the Ring Type, the default system rings have nine and the custom ringtones have three that can be set through the web page.

## **6.4 Voice Volume**

1. Press Menu ->Settings-> Enter->Basic Setting-> Enter->Voice Volume->Enter.
2. Use the navigation keys to turn down or turn up the voice volume, then press the key Save.

## **6.5 Time & Date**

1. Press Menu ->Settings->Enter->Basic Settings-> Enter->Time & Date->Enter.
2. You have two options to choose: Auto and Manual, use the navigation keys to choose, then press Save.

## **6.6 Greeting Words**

1. Press Menu ->Settings-> Enter->Basic Settings-> Enter->Greeting Words->Enter.
2. You can enter the message and press Save, it will display in the phone screen when the phone start up.

## **6.7 Language**

1. Press Menu ->Settings-> Enter->Basic Settings-> Enter->Language ->Enter.
2. F52 support three languages, you can use the navigation keys to choose. The default two languages are English and Chinese.

## **7 Advanced Settings of F52**

### **7.1 Accounts**

Press Menu->Enter->Advanced settings, and then input the password to enter the interface, the default password is 123. You can set it through the web page. Then choose Account then press Enter, you can do some sip settings.

### **7.2 Network**

Press Menu->Enter->Advanced settings, and then input the password to enter the interface. Then choose Network and press Enter, you can do network settings, you can refer to 2.2.1 Network settings.

### **7.3 Security**

Press Menu->Enter->Advanced settings, and then input the password to enter the interface. Then choose Security, you can configure Menu Password, Key lock Password, Key lock Status and whether to ban Outgoing.

### **7.4 Maintenance**

Press Menu->Enter->Advanced settings, and then input the password to enter the interface. Then choose Maintenance and press Enter, you can configure Auto Provision, Backup, and Upgrade.

### **7.5 Factory Reset**

Press Menu->Enter->Advanced settings, and then input the password to enter the interface. Then choose Factory Reset and press Enter, you can choose Yes or No.

# 8 Web Configuration

## 8.1 Introduction of configuration

### 8.1.1 Ways to configure

F52 has three different ways to different users.

- Use phone keypad.
- Use web browser (recommendatory way).
- Use telnet with CLI command.

### 8.1.2 Password Configuration

There are two levels to access to phone: root level and general level. User with root level can browse and set all configuration parameters, while user with general level can set all configuration parameters except SIP (1-2) or IAX2's that some parameters cannot be changed, such as server address and port. User will has different access level with different username and password.

- Default user with general level:
  - ◆ Username: guest
  - ◆ Password: guest
- Default user with root level:
  - ◆ Username: admin
  - ◆ Password: admin

The default password of phone screen menu is 123.

## 8.2 Setting via web browser

When this phone and PC are connected to network, enter the IP address of the wan port in this phone as the URL (e.g. <http://xxx.xxx.xxx.xxx/> or <http://xxx.xxx.xxx.xxx:xxxx/>).

If you do not know the IP address, you can look it up on the phone's display by pressing Status button.

The login page is as below picture.

**User:**   
**Password:**   
**Language:** English ▾

After you configure the IP phone, you need click save button in config under Maintenance in the left catalog to save your configuration. Otherwise the phone will lose your modification after power off and on.

## 8.3 Configuration via WEB

### 8.3.1 BASIC

#### 8.3.1.1 STATUS

STATUS		WIZARD		CALL LOG		LANGUAGE	
<b>Network</b>							
WAN				LAN			
Connection Mode	DHCP			IP Address	192.168.10.23		
MAC Address	00:a8:59:cc:b2:fc			DHCP Service	Enabled		
IP Address	192.168.2.5			Bridge Mode	Disabled		
IP Gateway	192.168.2.1						
<b>Accounts</b>							
SIP Line 1	@:5060			Unapplied			
SIP Line 2	@:5060			Unapplied			
SIP Line 3	@:5060			Unapplied			
SIP Line 4	@:5060			Unapplied			
SIP Line 5	@:5060			Unapplied			
SIP Line 6	@:5060			Unapplied			
IAX2	@:4569			Unapplied			

### Status

Field name	Explanation
------------	-------------



Network	Shows the configuration information on WAN and LAN port, including the connect mode of WAN port (Static, DHCP, PPPoE), MAC address, the IP address of WAN port and LAN port, ON or OFF of DHCP mode of LAN port and bridge mod
Accounts	Shows the phone numbers provided by the SIP LINE 1-2 servers and IAX2. The last line shows the version number .

### 8.3.1.2 WIZARD

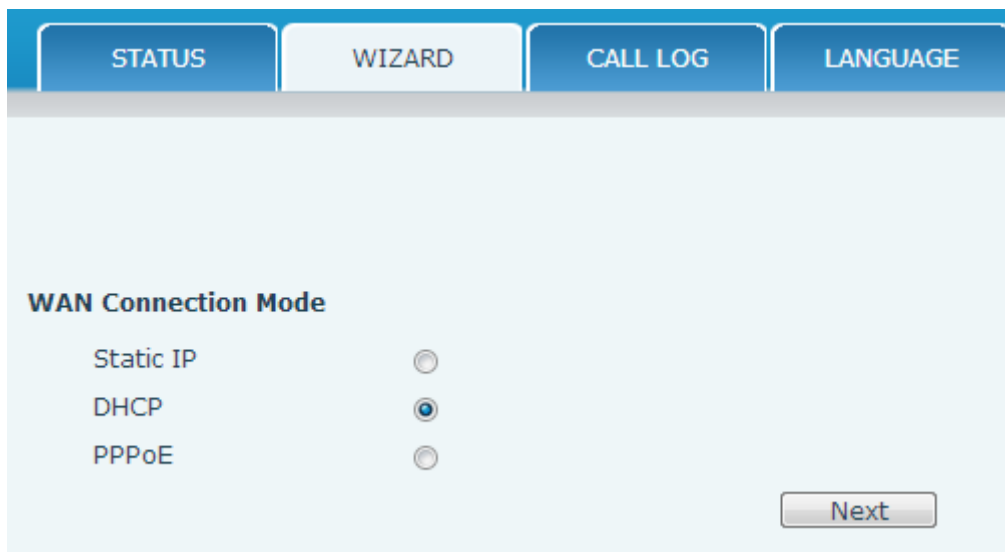

## Wizard

Please select the proper network mode according to the network condition. F52 provide three different network settings:

- Static: If your ISP server provides you the static IP address, please select this mode, and then finish Static Mode setting. If you don't know about parameters of Static Mode setting, please ask your ISP for them.
- DHCP: In this mode, you will get the information from the DHCP server automatically; need not to input this information artificially.
- PPPoE: In this mode, you must input your ADSL account and password.

You can also refer to 2.2.1 Network setting to speed setting your network.

Choose Static IP MODE, click **【NEXT】** can configure the network and

SIP(default SIP1) simply, also can browse too. Click **【BACK】** can return to the last page.

**Static IP Settings**

IP Address

Subnet Mask

IP Gateway

DNS Domain

Primary DNS

Secondary DNS

IP Address	Input the IP address distributed to you
Subnet Mask	Input the Netmask distributed to you.
IP Gateway	Input the Gateway address distributed to you.
DNS Domain	Set DNS domain postfix. When the domain which you input cannot be parsed, phone will automatically add this domain to the end of the domain which you input before and parse it again.
Primary DNS	Input your primary DNS server address.
Secondary DNS	Input your standby DNS server address.

**Quick SIP Settings**

Display Name

Server Address

Server Port

Authentication User

Authentication Password

SIP User

Enable Registration

Display Name	Set the display name.
Server Address	Input your SIP server address.
Server Port	Set your SIP server port.
Authentication User	Input your SIP register account name.
Authentication Password	Input your SIP register password.
SIP User	Input the phone number assigned by your VOIP service provider.
Enable Registration	Start to register or not by selecting it or not.

WAN	
Connection Mode	Static IP
Static IP Address	192.168.1.179
IP Gateway	192.168.1.1

---

SIP	
Server Address	
Account	
Phone Number	
Registration	Disabled

Display detailed information that you manual config.

Choose DHCP MODE, click **【Next】** can config SIP (default SIP1) simply, also can browse too. Click Back can return to the last page. Like Static IP MODE.

Choose PPPoE MODE, click **【Next】** can config the PPPoE account/password and SIP (default SIP1) simply, also can browse too.

Click **【Back】** can return to the last page. Like Static IP MODE.

PPPoE Settings	
Service Name	<input type="text" value="ANY"/>
User	<input type="text" value="user123"/>
Password	<input type="password" value="....."/>

PPPOE Server	Server name, if PPPOE service providers are no special requirements, this name is usually the default value.
User	Input your ADSL account
Password	Input your ADSL password

Notice: Click **【Finish】** button after finished your setting, IP Phone will save the setting automatically and reboot, After reboot, you can dial by the SIP account.

### 8.3.1.3 CALL LOG

You can query all the outgoing through this page.

Call Information		
Start Time	Duration	Dialed Calls

## Call log

Field name	explanation
Start Time	Display the start time of the outgoing record.
Duration	Display the conversation time of the outgoing record.
Dialed Calls	Display the account/protocol/line of the outgoing record.

### 8.3.1.4 LANGUAGE

The screenshot shows a configuration interface with a blue header containing four tabs: STATUS, WIZARD, CALL LOG, and LANGUAGE. The LANGUAGE tab is active. The main content area is light blue and contains two sections. The first section, titled 'Language', has a label 'Language Selection' and a dropdown menu currently set to 'English'. The second section, titled 'Greeting Words', has a label 'Greeting Words' and a dropdown menu, and a text input field containing the text 'VOIP PHONE'. An 'Apply' button is positioned at the bottom right of the configuration area.

## LANGUAGE

Field name	Field name
Language	Set the language of phone, English is default.
Greeting Words	The greeting words will display on LCD when phone is idle. It can support 12 chars. the default chars are VOIP PHONE.

Notice: the maximal length of the greeting message is twelve English characters and five Chinese characters.

## 8.3.2 NETWORK

### 8.3.2.1 WAN

**WAN Status**

Active IP Address	192.168.2.5
Current Subnet Mask	255.255.255.0
Current IP Gateway	192.168.2.1
MAC Address	00:a8:59:cc:b2:fc
MAC Timestamp	20130426

**WAN Settings**

Obtain DNS Server Automatically

Static IP  DHCP  PPPoE

**802.1X Settings**

User

Password

Enable 802.1X

### WAN Status

**WAN Status**

Active IP Address	192.168.2.5
Current Subnet Mask	255.255.255.0
Current IP Gateway	192.168.2.1
MAC Address	00:a8:59:cc:b2:fc
MAC Timestamp	20130426

---

Active IP Address      **The current IP address of the phone**

---

Current Subnet Mask      The current Netmask address

---

MAC Address      The current MAC address of the phone

---

Current IP Gateway      The current Gateway IP address

---

MAC Timestamp      Shows the time of getting MAC address

---

**WAN Settings**

Obtain DNS Server Automatically

Static IP  DHCP  PPPoE

Please select the proper network mode according to the network condition. F52 provide three different network settings:

- **Static:** If your ISP server provides you the static IP address, please select this mode, and then finish Static Mode setting. If you don't know about parameters of Static Mode setting, please ask your ISP for them.
- **DHCP:** In this mode, you will get the information from the DHCP server automatically; need not to input this information artificially.
- **PPPoE:** In this mode, you must input your ADSL account and password.

You can also refer to 2.2.1 Network setting to speed setting your network.

Obtain DNS server automatically	Select it to use DHCP mode to get DNS address, if you don't select it, you will use static DNS server. The default is selecting it.
---------------------------------	---

**WAN Settings**

Static IP       DHCP       PPPoE

IP Address:

Subnet Mask:

IP Gateway:

DNS Domain:

Primary DNS:

Secondary DNS:

If you user static mode, you need set it.

IP Address	Input the IP address distributed to you.
Subnet Mask	Input the Netmask distributed to you.
IP Gateway	Input the Gateway address distributed to you.
DNS Domain	Set DNS domain postfix. When the domain which you input cannot be parsed, phone will automatically add this domain to the end of the domain which you input before and parse it again.
Primary DNS	Input your primary DNS server address.
Secondary DNS	Input your standby DNS server address.

Static IP       DHCP       PPPoE

Service Name:

User:

Password:

If you uses PPPOE mode, you need to make the above setting.

Service Name	It will be provided by ISP.
User	Input your ADSL account.
Password	Input your ADSL password.

Note:

- 1) Click “Apply” button after finished your setting, IP Phone will save the setting automatically and new setting will take effect.
- 2) If you modify the IP address, the web will not response by the old IP address. You need input new IP address in the address column to login in the phone.
- 3) If networks ID which is DHCP server distributed is same as network ID which is used by LAN of system, system will use the DHCP IP to set WAN, and modify LAN’s networks ID (for example, system will change LAN IP from 192.168.10.1 to 192.168.11.1) when system uses DHCP client to get IP in startup; If system uses DHCP client to get IP in running status and network ID is also same as LAN’s, system will refuse to accept the IP to configure WAN. So WAN’s active IP will be 0.0.0.0.

### 8.3.2.2 LAN

LAN Settings ⓘ

IP Address

Subnet Mask

DHCP Service

NAT

Port Mirror  (Only works in the bridge mode!)

Enable Bridge Mode

### LAN Config

Field name	explanation
LAN IP Address	Specify LAN static IP
Subnet Mask	Specify LAN Netmask
DHCP Service	Select the DHCP server of LAN port or not. After you modify the LAN IP address, phone will amend and adjust the DHCP Lease Table and save the result amended automatically according to the IP address and Netmask. You need reboot the phone and the DHCP server setting will take effect.
NAT	Select NAT or not
Port Mirror	Select Port Mirror or not, it only works in bridge mode, the function of the port mirror is that copy

	the data stream from the WAN port to the LAN port of the phone.
Enable Bridge Mode	Select Bridge Mode or not: If you select Bridge Mode, the phone will no longer set IP address for LAN physical port, LAN and WAN will join in the same network. Click "Apply", the phone will reboot.
Notice: When LAN IP or bridge mode status is changed, the system will reboot!	
If you choose the bridge mode, the LAN configuration will be disabled.	

### 8.3.2.3 QoS&VLAN

The VOIP phone support 802.1Q/P protocol and DiffServ configuration. VLAN functionality can use different VLAN IDs by setting voice VLAN and data VLAN. The VLAN application of this phone is very flexible.

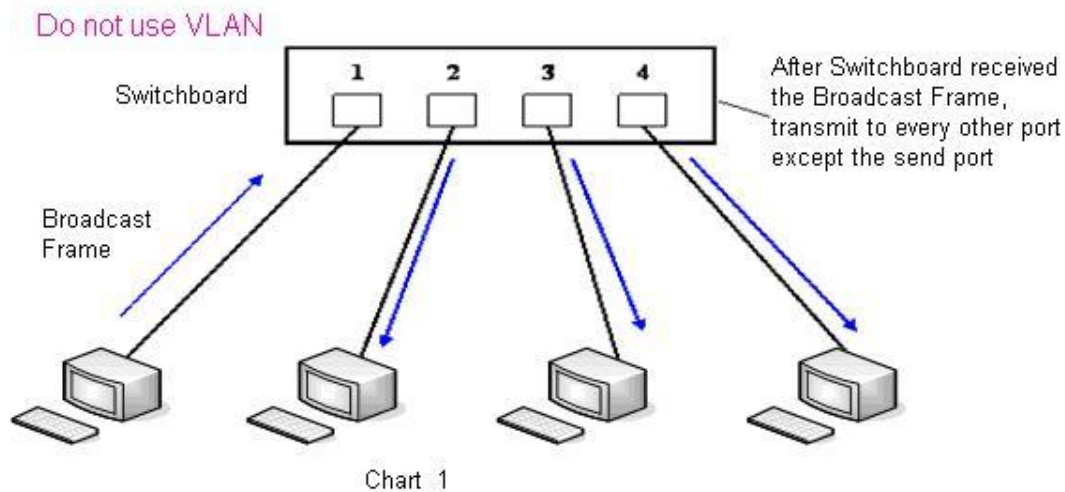



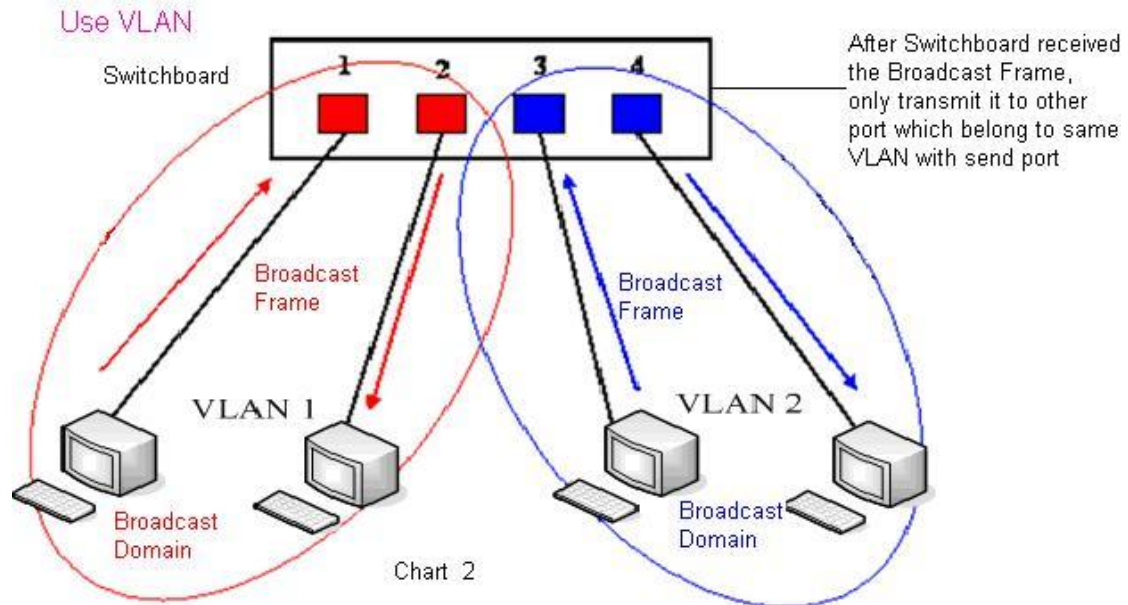

In chart 1, there is a layer 2 that switches without setting VLAN. Any broadcast frame will be transmitted to the other ports except the send port. For example, a broadcast information is sent out from port 1 then transmitted to port 2,3and 4.

In chart 2, red and blue indicate two different VLANs in the switch, and port 1 and port 2 belong to red VLAN, port 3 and port 4 belong to blue VLAN. If a broadcast frame is sent out from port 1, switch will transmit it to port 2, the other port in the red VLAN and not transmit it to port3 and port 4 in blue VLAN. By this means, VLAN divide the broadcast domain via restricting the range of broadcast frame transition.

Note: chart 2 use red and blue to identify the different VLAN, but in practice, VLAN uses different VLAN IDs to identify.

WAN	LAN	QoS&VLAN	SERVICE PORT	DHCP SERVICE	TIME&DATE
<b>Link Layer Discovery Protocol (LLDP) Settings</b>					
Enable LLDP	<input type="checkbox"/>	Packet Interval(1~3600)	<input type="text" value="60"/>	second(s)	
Enable Learning Function	<input type="checkbox"/>				
<b>Quality of Service (QoS) Settings</b>					
Enable DSCP	<input type="checkbox"/>	SIP DSCP	<input type="text" value="0"/>	(0~63)	
Audio RTP DSCP	<input type="text" value="0"/>	(0~63)			
<b>WAN Port VLAN Settings</b>					
Enable WAN Port VLAN	<input type="checkbox"/>	WAN Port VLAN ID	<input type="text" value="0"/>	(0~4095)	
SIP 802.1P Priority	<input type="text" value="0"/>	(0~7)	Audio 802.1P Priority	<input type="text" value="0"/>	(0~7)
<b>LAN Port VLAN Settings</b>					
LAN Port VLAN Mode	<input type="text" value="Follow WAN"/>	LAN Port VLAN ID	<input type="text" value="0"/>	(0~4095)	
<input type="button" value="Apply"/>					

## QoS & VLAN Configuration

Field name	explanation
Link Layer Discovery Protocol (LLDP) Settings	
Enabel LLDP	Enable LLDP by selecting it.
Enable Learning Funcion	After enabling LLDP Learn, telephone can automatically learn the data of DSCP, 802.1p, VLAN ID from the switch. If the data is different from the data of the LLDP server, telephone will change its own value as the value of the switch (Synchronous with VLAN in switch).
Package Interval(1-3600)	The time interval of sending LLDP Packet.
<b>Quality of Service(QOS) Settings</b>	
Enable DSCP	Enable DSCP by selecting it.
SiP DSCP	Specify the value of the SIP DSCP.
Audio RTP DSCP	Specify the value of the Audio RTP DSCP.
<b>WAN Port VLAN Settings</b>	
Enable WAN Port	Enable WAN Port VLAN by selecting it.

VLAN	
WAN Port VLAN ID	Specify the value of the WAN Port VLAN ID, the range of the value is 0-4095.
SIP 802.1p Priority	Specify the value of the sip 802.1p priority, the range of the value is 0-7.
Audio 802.1p Priority	Specify the value of the audio 802.1p priority, the range of the value is 0-7.
LAN Port VLAN Settings	
LAN Port Vlan	Follow WAN: Follow the WAN ID. Disable: Disable Port VALN. Enable: Enable Port VLAN and specify the Port VLAN ID different from WAN ID.
LAN Port VLAN ID	Specify the value of the Port VLAN ID different from WAN ID, the range of the value is 0-4095.

#### 8.3.2.4 Service Port

You can set the port of telnet/HTTP/RTP by this page.

### Service Port

Field name	explanation
<b>Service Port Settings</b>	
Web Server Type	Specify Web Server Type.
HTTP Port	Set web browser port, the default is 80 port, if you want to enhance system safety, you'd better change it into non-80 standard port; Example: The IP address is 192.168.1.70. and the port value is 8090, the accessing address is

http://192.168.1.70:8090.

HTTPS Port	Before using the https, you must download https authentication certification into the phone, then set web browser port, the default is 443 port, if you want to enhance system safety, you'd better change it into non-443 standard port. You can access to the web in https after rebooting the phone.
Telnet Port	Set Telnet Port, the default is 23.
RTP Port Range Start	Set the RTP Start Port. It is dynamic allocation.
RTP Port Quantity	Set the maximum quantity of RTP Port, the default is 200.

**Notice:**

- 1) You need save the configuration and reboot the phone after set this page.
- 2) Please REBOOT the system if you modify the HTTP or telnet port number (the new number should be greater than 1024).
- 3) If you set 0 for the HTTP port, it will disable HTTP service.

### 8.3.2.5 DHCP SERVICE

The screenshot shows the DHCP SERVICE configuration page. It includes a navigation bar with tabs for WAN, LAN, QoS&VLAN, SERVICE PORT, DHCP SERVICE, and TIME&DATE. The DHCP SERVICE tab is selected. The page displays a DHCP Client Table with columns for Leased IP Address and Client MAC Address. Below this is a DHCP Lease Table with columns for Name, Start IP, End IP, Leased Time, Subnet Mask, IP Gateway, and DNS. The table contains one entry for 'lan' with IP 192.168.10.24, End IP 192.168.10.53, Leased Time 1440, Subnet Mask 255.255.255.0, IP Gateway 192.168.10.23, and DNS 192.168.10.23. At the bottom is a DHCP Lease Table Settings section with input fields for Leased Table Name, Start IP Address, End IP Address, Leased Time (with a 'minute(s)' label), Subnet Mask, IP Gateway, and DNS Server Address, followed by an 'Add' button.

## DHCP SERVICE

Field name	explanation
DHCP Lease Table	IP-MAC mapping table. If the LAN port of the phone connects to a device, this table will show

the IP and MAC address of this device.

Shows the DHCP Lease Table, the unit of Lease time is Minute.

Lease Table Name	Specify the name of the lease table.
Start IP Address	Set the start IP address of the lease table.
End IP Address	Set the end IP address of the lease table, the network device connected to LAN port will get IP address between Start IP and End IP by DHCP.
Leased Time	Set the Lease Time of the lease table.
Subnet Mask	Set the Netmask of the lease table.
IP Gateway	Set the Gateway of the lease table.
DNS	Set the default DNS server IP of the lease table; Click the <b>Add</b> button to submit and add this lease table.

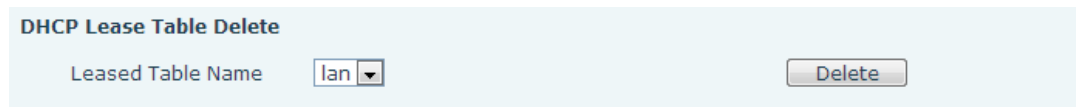

The screenshot shows a light blue panel titled "DHCP Lease Table Delete". It contains a label "Leased Table Name" followed by a dropdown menu with "lan" selected. To the right is a "Delete" button.

Select name of lease table, click the **Delete** button will delete the selected lease table from DHCP lease table.



The screenshot shows a light blue panel titled "DNS Relay". It contains a label "Enable DNS Relay" followed by a checked checkbox. To the right is an "Apply" button.

Enable DNS Relay Select DNS Relay, the default is enabled. Click the **Apply** button to become effective.

**Notice:**

- 1) The size of lease table cannot be larger than the quantity of C network IP address. We recommend you to use the default lease table and not modify it.
- 2) If you modify the DHCP lease table, you need save the configuration and reboot.

**8.3.2.6 TIME&DATE**

Setting time zone and SNTP (Simple Network Time Protocol) server according to your location, you can also manually adjust date and time in this web page.

WAN	LAN	QoS&VLAN	SERVICE PORT	DHCP SERVICE	TIME&DATE
-----	-----	----------	--------------	--------------	-----------

### Simple Network Time Protocol (SNTP) Settings

Enable SNTP   
 Enable DHCP Time   
 Primary Server   
 Secondary Server   
 Timezone   
 Resync Period  second(s)  
 12-Hour Clock   
 Date Format

---

### Daylight Saving Time Settings

Enable   
 Offset  minutes(s)  
 Month    
 Week    
 Day    
 Hour

---

### Manual Time Settings

Year   
 Month   
 Day   
 Hour   
 Minute

## TIME&DATE

Field Name	Explanation
Simple Network Time Protocol (SNTP) Settings	
Enable SNTP	Enable SNTP by selecting it.
Enable DHCP Time	Enable DHCP Time by selecting it, then the phone will automatically synchronize the standard time.
Primary Server	Set SNTP Primary Server IP address.
Secondary Server	Set SNTP Secondary Server IP address.
Time Zone	Select the Time zone according to your location.
Resync Period	Set the time out, the default is 60 seconds.
12 -Hour Clock	Switch the time mechanism between 12 hours and 24 hours. Default is 24 hours mode.

Date format	Specify the date format.
<b>Daylight Saving Time Settings</b>	
Enable	Enable daylight saving time.
Offset(minutes)	Setup the variety length.
Month	Setup start and end month.
Week	Setup start and end week.
Day	Setup start and end day.
Hour	Setup start and end hours.
Minute	Setup start and end minutes.

### Manual Time Settings

**Manual Time Settings**

Year

Month

Day

Hour

Minute

Notice: First of all, you need to disable the SNTP service, and above the date hours minutes each of which is required to complete and submit to make manual.

## 8.3.3 VOIP

### 8.3.3.1 SIP

Set your SIP server in the following interface.

SIP
IAX2
STUN
DIAL PEER

**SIP Line** SIP 1 ▼

---

**Basic Settings >>**

Status	Unapplied	Domain Realm	<input type="text"/>
Server Address	<input type="text"/>	Proxy Server Address	<input type="text"/>
Server Port	<input type="text" value="5060"/>	Proxy Server Port	<input type="text"/>
Authentication User	<input type="text"/>	Proxy User	<input type="text"/>
Authentication Password	<input type="text"/>	Proxy Password	<input type="text"/>
SIP User	<input type="text"/>	Backup Server Address	<input type="text"/>
Display Name	<input type="text"/>	Backup Server Port	<input type="text" value="5060"/>
Enable Registration	<input type="checkbox"/>	Server Name	<input type="text"/>

### Codecs Settings >>

#### Disabled Codecs

G.711A  
G.711U  
G.722  
G.723.1  
G.726-32  
G.729AB



#### Enabled Codecs



### Advanced SIP Settings >>

Forward Type	<input type="text" value="Disabled"/>	Enable Hotline	<input type="checkbox"/>
Forward Number	<input type="text"/>	Hotline Number	<input type="text"/>
No Ans. Fwd Wait Time	<input type="text" value="60"/> (0~120)second(s)	Warm Line Wait Time	<input type="text" value="0"/> (0~9)second(s)
Transfer Timeout	<input type="text" value="0"/> second(s)	BLF Server	<input type="text"/>
SIP Encryption	<input type="checkbox"/>	Enable Auto Answer	<input type="checkbox"/>
SIP Encryption Key	<input type="text"/>	Auto Answer Timeout	<input type="text" value="60"/> second(s)
RTP Encryption	<input type="checkbox"/>	Enable Session Timer	<input type="checkbox"/>
RTP Encryption Key	<input type="text"/>	Session Timeout	<input type="text" value="0"/> second(s)
Subscribe For MWI	<input type="checkbox"/>	Conference Type	<input type="text" value="Local"/>
MWI Number	<input type="text"/>	Conference Number	<input type="text"/>
Subscribe Period	<input type="text" value="3600"/> second(s)	Registration Expires	<input type="text" value="3600"/> second(s)

Enable Service Code	<input type="checkbox"/>	DND Off Code	<input type="text"/>
DND On Code	<input type="text"/>	Always CFwd Off Code	<input type="text"/>
Always CFwd On Code	<input type="text"/>	Busy CFwd Off Code	<input type="text"/>
Busy CFwd On Code	<input type="text"/>	No Ans. CFwd Off Code	<input type="text"/>
No Ans. CFwd On Code	<input type="text"/>	Anonymous Off Code	<input type="text"/>
Anonymous On Code	<input type="text"/>	Keep Alive Type	<input type="text" value="SIP Option"/>
Keep Alive Interval	<input type="text" value="60"/> second(s)	User Agent	<input type="text"/>
Server Type	<input type="text" value="COMMON"/>	DTMF Type	<input type="text" value="RFC2833"/>
RFC Protocol Edition	<input type="text" value="RFC3261"/>	DTMF SIP INFO Mode	<input type="text" value="Send 10/11"/>
Local Port	<input type="text" value="5060"/>	Ring Type	<input type="text" value="Default"/>
Anonymous Call Edition	<input type="text" value="None"/>	Enable Rport	<input type="checkbox"/>
Keep Authentication	<input type="checkbox"/>	Enable PRACK	<input type="checkbox"/>
Ans. With a Single Codec	<input type="checkbox"/>	Enable Long Contact	<input type="checkbox"/>
Auto TCP	<input type="checkbox"/>	Convert URI	<input checked="" type="checkbox"/>
Enable Strict Proxy	<input type="checkbox"/>	Dial Without Registered	<input type="checkbox"/>
Enable GRUU	<input type="checkbox"/>	Ban Anonymous Call	<input type="checkbox"/>
Enable Displayname Quote	<input type="checkbox"/>	Enable DNS SRV	<input type="checkbox"/>
Enable user=phone	<input checked="" type="checkbox"/>	Enable Missed Call Log	<input checked="" type="checkbox"/>
Click To Talk	<input type="checkbox"/>		

### SIP Global Settings >>

Strict Branch	<input type="checkbox"/>	Enable Group	<input type="checkbox"/>
Registration Failure Retry Time	<input type="text" value="32"/> second(s)		

Apply



## SIP Config

Field name	explanation
<b>SIP Line</b>	
Choose line to set info about SIP, there are 4 lines to choose. You can switch by <b>【Load】</b> button.	
<b>Basic Settings</b>	
Status	Shows if the phone has been registered the SIP server or not; or so, show Unapplied.
Server Address	Input your SIP server address.
Server Port	Set your SIP server port.
Authentication User	Input your SIP register account name.
Authentication Password	Input your SIP register password.
SIP User	Input the phone number assigned by your VoIP service provider. Phone will not register if there is no phone number configured.
Display Name	Set the display name.
Proxy Server Address	Set proxy server IP address (Usually, Register SIP Server configuration is the same as Proxy SIP Server. But if your VoIP service provider gives different configurations between Register SIP Server and Proxy SIP Server, you need make different settings).
Proxy Server Port	Set your Proxy SIP server port.
Proxy User	Input your Proxy SIP server account.
Proxy Password	Input your Proxy SIP server password.
Domain Realm	Set the sip domain if needed, otherwise this VoIP phone will use the Register server address as sip domain automatically. (Usually it is same with registered server and proxy server IP address).
Backup Server Address	Input the Backup Server Address, if the primary server is unavailable, then the phone will enable the Backup Server Address.
Backup Server Port	Specify the Backup Server Port.
Enable Registration	Start to register or not by selecting it or not.
<b>Codecs Settings</b>	
Disable Codecs/Enable Codecs	Use the navigation keys to highlight the desired one in the Enable/Disable Codecs list, and press the desired to move to the other list.
<b>Advanced SIP Setting</b>	
Select call forward mode, the default is Disabled.	

Forward Type	<p>Off: Close down calling forward.</p> <p>Busy: If the phone is busy, incoming calls will be forwarded to the appointed phone.</p> <p>No answer: If there is no answer, incoming calls will be forwarded to the appointed phone after a specific.</p> <p>Always: Incoming calls will be forwarded to the appoint phone immediately.</p> <p>The phone will prompt the incoming while doing forward.</p>
Forward Number	Specify the number you want to forward.
No Answer Forward Wait Time	Specify the No Answer Forward Delay Time, if the Forward Type is No answer, incoming calls will be forwarded after the no answer forward wait time.
Enable Hot Line	Specify Hot Line by selecting it.
Hot Line Number	Specify Hot Line Number, the phone dial the hot line number automatically at hands-free mode or handset mode after warm line time.
Warm Line Wait Time	Specify the Warm Line Time.
Transfer Timeout	For the phone supports the transfer of certain special features server, set interval time between sending "bye" and hanging up after the phone transfers a call.
BLF Server	Ordinary BLF application is that the phone send subscription package to the registered server, if your server does not support subscription package, please input the BLF server so that it can separate register server and BLF server
SIP Encryption	Enable/Disable SIP Encryption.
SIP Encryption Key	Set the key for sip encryption.
RTP Encryption	Enable/Disable RTP encryption.
RTP Encryption Key	Set the key for RTP encryption.
Enable Auto Answer	Enable Auto Answer by selecting it.
Auto Answer Timeout	Specify Auto Answer Time, the phone auto answers the incoming call after Auto Answer Time.
Enable Session Timer	Set Enable/Disable Session Timer, whether support RFC4028.It will refresh the SIP sessions.
Session Timeout	Set the session timeout.
Subscribe for MWI	Enable the Subscribe for MWI by selecting it, the phone will send subscribe message for MWI to the SIP Server.

MWI Number	Specify the MWI Number; Please contact your system administrator for the connecting code. Different systems have different codes.
Subscribe Period(s)	Overtime of resending subscribe packet. Suggest using the default configuration.
Conference Type	Specify the Conference Type, if you select the local, you needn't input the conference number.
Conference Number	Specify the network conference number, please contact your system administrator for the network conference number.
Registration Expire(s)	Set expire time of SIP server register, default is 60 seconds. If the register time of the server requested is longer or shorter than the expired time set, the phone will change automatically the time into the time recommended by the server, and register again.
Enable Service Code	If you want to realize the following function by the server, please enter the On Code and Off Code option, then when you choose to enable/disable following function on your IP phone, it will send message to the server, and the server will turn on/off the function immediately.
DND On Code	Set the DND On Code, When you press the DND hot key, the phone will send a message to the server, and the server will turn on the DND function. Then any calls to the extension will be rejected by the server automatically. And the incoming call record will not be displayed in the Call History.
DND Off Code	Set the DND Off Code, When you press the DND hot key, the phone will send a message to the server, and the server will turn off the DND function.
Always CFwd On Code	Set the Always CFwd On Code, when you choose to enable the always forward function on your phone, it will send message to the server, and the server will turn on the function immediately. When there are calls to the extension, the server will always forward it to the set number automatically. And the IP phone will not show the record in the call history anymore.
Always CFwd Off Code	Set the Always CFwd Off Code, when you choose to disable the always forward function on your phone, it will send message to the server, and the

	server will turn off the function immediately.
Busy CFwd On Code	Set the Busy CFwd On Code, when you choose to enable the busy forward function on your phone, it will send message to the server, and the server will turn on the function immediately. When there are calls to the extension, the server will forward it to the set number automatically based the forward type. And the IP phone will not show the record in the call history anymore.
Busy CFwd Off Code	Set the Busy CFwd Off Code, when you choose to disable the busy forward function on your phone, it will send message to the server, and the server will turn off the function immediately.
No Answer CFwd On Code	Set the No Answer CFwd On Code, when you choose to enable the on answer forward function on your phone, it will send message to the server, and the server will turn on the function immediately. When there are calls to the extension, the server will forward it to the set number automatically based the forward type. And the IP phone will not show the record in the call history anymore.
No Answer CFwd Off Code	Set the No Answer CFwd Off Code, when you choose to disable the busy forward function on your phone, it will send message to the server, and the server will turn off the function immediately.
Anonymous On Code	Set the Anonymous On Code, When you choose to enable the anonymous call function on your IP phone, it will send information to the server, and the server will enable the anonymous call function for your IP phone automatically.
Anonymous Off Code	Set the Anonymous Off Code, When you choose to disable the anonymous call function on your IP phone, it will send information to the server, and the server will disable the anonymous call function for your IP phone automatically.
Keep Alive Type	Specify the keep alive type, if the type is option, the phone will send option sip message to server every NAT Keep Alive Period(s), then the server responses with 200 to keep alive. If the type is UDP, the phone will send UDP message to server to keep alive every NAT Keep Alive Period(s).

Keep Alive Interval	Set examining interval of the server, default is 60 seconds.
User Agent	Set the user agent if have, the default is VoIP Phone 1.0.
DTMF Type	Select DTMF sending mode, there are three modes: <ul style="list-style-type: none"> <li>● DTMF_RELAY</li> <li>● DTMF_RFC2833</li> <li>● DTMF_SIP_INFO</li> </ul> Different VoIP Service providers may provide different modes.
DTMF SIP INFO Mode	There are two options: send 10/11 and send * / #
Local Port	Set sip port of each line.
Ring Type	Set ring type of each line.
Enable Via Rport	Enable/Disable system to support RFC3581. Via rport is special way to realize SIP NAT.
Enable PRACK	Enable or disable SIP PRACK function, suggest use the default config.
Enable Long Contact	Set more parameters in contact field; connection with SEM server.
Convert URI	Convert # to %23 when send the URI.
Dial Without Registered	Set call out by proxy without registration;
Ban Anonymous Call	Set to ban Anonymous Call;
Enable DNS SRV	Support DNS looking up with _sip.udp mode.
Server Type	Select the special type of server which is encrypted, or has some unique requirements or call flows.
RFC Protocol Edition	Select SIP protocol version to adapt for the SIP server which uses the same version as you select. For example, if the server is CISCO5300, you need to change to RFC2543; else phone may not cancel call normally. System uses RFC3261 as default.
Transport Protocol	Set transport protocols, TCP or UDP;
Anonymous call Edition	Set Anonymous call out safely; Support RFC3323and RFC3325;
Keep Authentication	Enable/Disable Keep Authentication System will take the last authentication field which is passed the authentication by server to the request packet. It will decrease the server's repeat authorization work, if it is enable.
Answer With A Single Codec	Enable/Disable the function when call is incoming, phone replies SIP message with just

	one codec which phone supports.
Auto TCP	Set to use automatically TCP protocol to guarantee usability of transport as message is above 1300 byte
Enable Strict Proxy	Support the special SIP server-when phone receives the packets sent from server,phone will use the source IP address, not the address in via field.
Enable GRUU	Set to support GRUU
Enable Display name Quote	Set to make quotation mark to display name as the phone sends out signal, in order to be compatible with server.
Enable user=phone	Enable user=phone by selecting it, it is contained in the invite sip message, in order to be compatible with server.
Enable Missed Call Log	Enable the missed call log by it, the phone will save the missed call log into the call history record and display the missed calls on the idle screen, or won't save the missed call log into the call history record and display the missed calls on the idle screen.
Click to talk	Set click to Talk (need practical software support).
Enable BLF List	Enable BLF List by selecting it, BLF list is a function which can monitor the group status, it is not one to one monitoring, but the information feedback from the server to decide which BLF list will monitor.
Use VPN	Phone use vpn ip to communicate
BLF List Number	Specify the BLF List Number.
<b>SIP Global Settings</b>	
Strict Branch	Enable the Strict Branch, the value of the branch must be in the beginning of z9hG4k in via field of the invite sip message received, or the phone won't response to the invite sip message. Notice: the deployment will become effective in all sip lines.
Enable Group	Enable Group by selecting it, then the phone enable the sip group backup function. Notice: the deployment will become effective in all sip lines.
Registration Failure Retry Time	Specify the registration failure retry time, if the phone register failed, the phone will register again after registration failure retry time.

Notice: the deployment will become effective in all sip lines.

### 8.3.3.2 IAX2

**IAX2**

Status Unapplied

Server Address

Server Port

Account

Password

Phone Number

Local Port

Voice Mail Number

Voice Mail Text

Echo Test Number

Echo Test Text

Refresh Time  second(s)

Enable Registration

Enable G.729AB

### IAX2 Config

Field name	explanation
Status	Shows if the phone has been registered the IAX2 server or not.
Server Address	Input your IAX2 server address.
Server Port	Set your IAX2 server port, the default is 4569.
Account	Input your IAX2 register account name.
Password	Input your IAX2 register password.
Phone Number	Input your assigned phone number (usually it is same you're your IAX2 account name).
Local Port	Set your local sport, the default is 4569.
Voice Mail Number	Specify the voice mail's number.

Voice Mail Text	Specify the voice mail's name.
Echo Test Number	Set echo test number. If IAX2 server supports echo test, and echo test number is non-numeric, system could set an echo test number to replace the echo test text. So user can dial the numeric number to test echo voice test. This function is provided with server to make endpoint to test whether endpoint could talk through server normally.
Echo Test Text	Specify echo test text's name.
Refresh Time	Set expire time of IAX2 server register, you can set it between 60 and 3600 seconds.
Enable Registration	Start to register the IAX2 server or not by selecting it or not.
Enable G.729AB	Enable or disable code G.729 by selecting it or not.

### 8.3.3.3 Stun

In this web page, you can config SIP STUN.

STUN: By STUN server, the phone in private network could know the type of NAT and the NAT mapping IP and port of SIP. The phone might register itself to SIP server with global IP and port to realize the device both calling and being called in private network.

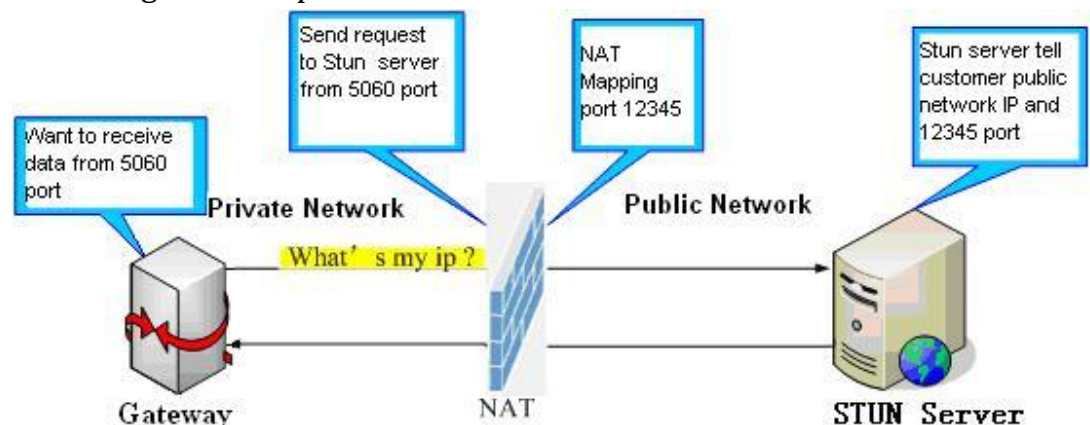



SIP
IAX2
STUN
DIAL PEER

---

**Simple Traversal of UDP through NATs (STUN) Settings**

STUN NAT Traversal FALSE

Server Address

Server Port

Binding Period  second(s)

SIP Waiting Time  millisecond(s)

Local SIP Port

---

**SIP Line Using STUN**

▼

Use STUN

## STUN

Field name	explanation
Simple Traversal of UDP through NATs (STUN) Settings	
STUN NAT Traversal	Shows STUN NAT Transverse estimation, true means STUN can penetrate NAT, while False means not.
Server Address	Set your SIP STUN Server IP address.
Server Port	Set your SIP STUN Server Port.
Blinding Period(s)	Set STUN blinding period(s). If NAT server finds that a NAT mapping is idle after time out, it will release the mapping and the system need send a STUN packet to keep the mapping effective and alive.
SIP Waiting Time	Specify the sip wait stun time; you can input the time depended on your network condition.
Local SIP Port	Configuration the local SIP Port, the default value is5060(this port immediate effect ,modify, SIP call will use the modified port communication )
<b>Sip Line Using STUN</b>	

**SIP Line Using STUN**

SIP 1

Use STUN

Apply

Choose line to set info about SIP, There are 2 lines to choose.

Use STUN Enable/Disable SIP STUN.

**Notice:** SIP STUN is used to realize SIP penetration to NAT. If your phone configures STUN Server IP and Port (default is 3478), and enable SIP Stun, you can use the ordinary SIP Server to realize penetration to NAT.

### 8.3.3.4 DIAL PEER

This functionality offers you more flexible dial rule, you can refer to the following content to know how to use this dial rule. When you want to dial an IP address, the entry of IP addresses is very cumbersome, but by this functionality, you can set number 156 to replace 192.168.1.119 here.

Dial Peer Table

Number	Destination	Port	Mode	Alias	Suffix	Del Length
156	192.168.1.119	5060	SIP	no alias	no suffix	0

When you want to dial a long distance call to Beijing, you need dial an area code 010 before local phone number, but you can also dial number 1 instead of 010 after we make a setting according to this dial rule. For example, you want to dial 01062213123, but you need dial only 162213123 to realize your long distance call after you make this setting.

Dial Peer Table

Number	Destination	Port	Mode	Alias	Suffix	Del Length
1T	0.0.0.0	5060	SIP	rep:010	no suffix	1

To save the memory and avoid abundant input of user, add the follow functions:

Dial Peer Table

Number	Destination	Port	Mode	Alias	Suffix	Deleted Length
13xxxxxxxx	0.0.0.0	5060	SIP	add:0	no suffix	0
13[5-9]xxxxxxxx	0.0.0.0	5060	SIP	add:0	no suffix	0

1. Increase in x matches any single digit, for example:

If user makes the above configuration, after user dials 11 digit numbers started with 13, the phone will send out 0 plus the dialed numbers automatically.

2. [] Specifies a range that will match digit. It may be a range, a list of ranges separated by commas, or a list of digits.

If user makes the above configuration, after user dials 11 digit numbers started with from 135 to 139, the phone will send out 0 plus the dialed numbers automatically.

Use this phone you can realize dialing out via different lines without switch in web interface.

**Dial Peer Table**

Number	Destination	Port	Mode	Alias	Suffix	Deleted Length
13xxxxxxxxxx	0.0.0.0	5060	SIP	add:0	no suffix	0
13[5-9]xxxxxxxxxx	0.0.0.0	5060	SIP	add:0	no suffix	0
156	192.168.1.119	5060	SIP	no alias	no suffix	0
1T	0.0.0.0	5060	SIP	rep:010	no suffix	1

---

**Add Dial Peer**

Phone Number

Destination(Optional)

Port(Optional)

Alias(Optional)

Call Mode SIP

Suffix(Optional)

Deleted Length(Optional)

---

**Dial Peer Option**

13xxxxxxxxxx

## DIAL PEER

Field name	explanation
Phone number	There are two types of matching conditions: one is full matching, the other is prefix matching. In the Full matching, you need input your desired phone number in this blank, and then you need dial the phone number to realize calling to what the phone number is mapped. In the prefix matching, you need input your desired prefix number and T; then dial the prefix and a phone number to realize calling to what your prefix number is mapped. The prefix number supports at most 30 digits.
Destination	Set Destination address. This is optional config item. If you want to set peer to peer call, please input destination IP address or domain name. If you want to use this dial rule on SIP2 line, you need input 255.255.255.255 or 0.0.0.2 in it.SIP3 into 0.0.0.3
Port	Set the Signal port, the default is 5060 for SIP.
Alias	Set alias. This is optional config item. If you don't set Alias, it will show no alias.

Note: There are four types of aliases.

- 1) Add: xxx, it means that you need dial xxx in front of phone number, which will reduce dialing number length.
- 2) All: xxx, it means that xxx will replace some phone number.
- 3) Del: It means that phone will delete the number with length appointed.

4) Rep: It means that phone will replace the number with length and number appointed.

You can refer to the following examples of different alias application to know more how to use different aliases and this dial rule.

Call Mode	Select different signal protocol, SIP or IAX2
Suffix	Set suffix, this is optional config item. It will show no suffix if you don't set it.
Delete Length	Set delete length. This is optional config item. For example: if the delete length is 3, the phone will delete the first 3 digits then send out the rest digits. You can refer to examples of different alias application to know how to set delete length.

The following describes how to configure the number IP table to achieve the configuration of multiple accounts simultaneously:

8T	0.0.0.2	5060	SIP	del	no suffix	1
9T	0.0.0.0	5060	SIP	del	no suffix	1

9T means when you configure the SIP1 server and register, then the user through all SIP1 call to dial a 9 before the number;

8T means when you configure the SIP2 server and register, then the user through all the numbers before calling SIP2 dial 8;

2T	0.0.0.0	4569	IAX2	del	no suffix	1
----	---------	------	------	-----	-----------	---

2T means when you configure the IAX2 server and register, then the user through all the IAX2 protocol number before the call can dial 2.

Note: For compatibility with 1.6 functions in the 1.7 version of the configuration file, add "Dialpeer With Line:" This field indicates whether to enable the on-line inquiry function, 0 is not enabled, 1 means enabled. The default is 0.

Differences are as follows:

1. Not enabled on-line inquiry

The function and the 1.6 version of the function is the same.

Type: This rule indicates what protocol needs to go.

Destination: indicates the destination address.

0.0.0.1 represents go sip1 line

0.0.0.2 represents go sip2 line

0.0.0.x represents go sipx line

(For compatibility with old code 0.0.0.0 means go sip1 line, 255.255.255.255 indicates go sip2 line)

Configuration examples are as follows:

2T	255.255.255.255	5060	SIP	del	no suffix	1
3T	0.0.0.0	4569	IAX2	del	no suffix	1

If the phone dial 21111, the fact is through SIP2 and called number is 1111.

If the phone dial 32222, the fact is through IAX2 and called number is 2222.

2. Enable on-line query capabilities

Enable on-line query function on the premise that: The phone must be multi-line products, you can choose when dialing protocol and line. So that each end of the dial, and also selected protocol and line.

Dialpeer table in the query, the first comparison dialing protocol is selected in the table and dialpeer agreement, if the same, continue down the match, otherwise, check the next one.

Step match line information, comparing the selected dial-up line is a line in the table and dialpeer is the same, if the same, continue down the match, otherwise the next query.

The third step is for a prefix or exact match.

Mode: to sip, it means that this rule is only used for sip protocol calls; iax2, it means that this rule is only used iax2 protocol calls.

Destination: indicates the destination address.

0.0.0.1 Indicates that the rule only calls for sip1 online

0.0.0.2 Indicates that the rule only calls for sip2 online

0.0.0.x Indicates that the rule only calls for sipX online

0.0.0.0 Indicates that the rules used in all online calls

Configuration Application examples

3T	0.0.0.0	4569	IAX2	del	no suffix	1
2T	0.0.0.0	5060	SIP	del	no suffix	1

The handset off-hook exhale (if SIP1 registration is successful, the default is SIP1) If the dial 21111, then exhaled directly through SIP1 and the called number is 21111

If the phone off-hook exhale (if SIP1 registration is successful, the default is SIP1) If dialing 32222, directly and through SIP1 outgoing called number is 32222

To make the configuration take effect dialpeer function,

Only when the handset off-hook exhaled choose SIP2, and dials 21111, the corresponding rule is matched by SIP2 exhaled and the called number is 1111

Only when the handset off-hook exhaled Select IAX2, and dials 32222, the corresponding rule is matched by IAX2 outgoing and called number is 2222

### Examples of different alias application

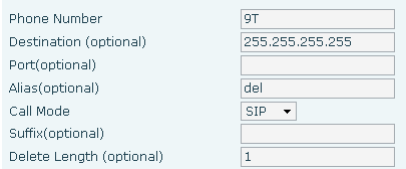
Set by web	explanation	example
	<p>You need set phone number, Destination, Alias and Delete Length. Phone number is XXXT; Destination is 255.255.255.255 (0.0.0.2) and Alias is del. This means any phone No. that starts with your set phone number will</p>	<p>If you dial "93333", the SIP2 server will receive "3333".</p>

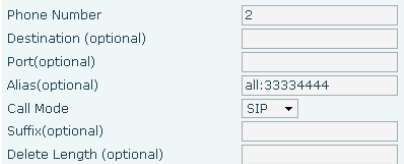
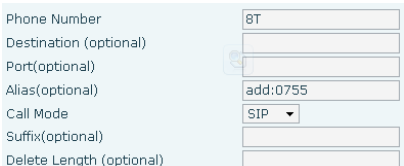
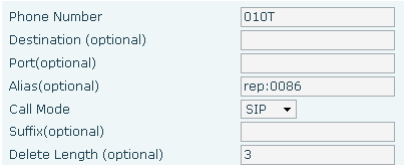
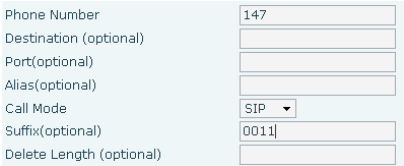
	<p>be sent via SIP2 line after the first several digits of your dialed phone number are deleted according to delete length.</p>	
	<p>This setting will realize speed dial function, after you dialing the numeric key “2”, the number after all will be sent out.</p>	<p>When you dial “2”, the SIP1 server will receive 33334444.</p>
	<p>The phone will automatically send out alias number adding your dialed number, if your dialed number starts with your set phone number.</p>	<p>When you dial “8309”, the SIP1 server will receive “07558309”.</p>
	<p>You need set Phone Number, Alias and Delete Length. Phone number is XXXT and Alias is rep: xxx If your dialed phone number starts with your set phone number, the first digits same as your set phone number will be replaced by the alias number specified and New phone number will be send out.</p>	<p>When you dial “0106228”, the SIP1 server will receive “86106228”.</p>
	<p>If your dialed phone number starts with your set phone number. The phone will send out your dialed phone number adding suffix number.</p>	<p>When you dial “147”, the SIP1 server will receive “1470011”.</p>

## 8.3.4 PHONE

### 8.3.4.1 AUDIO

In this page, you can configure voice codec, input/output volume and so on.

### AUDIO Configuration

Field name	explanation
First Codec	The first preferential DSP codec: G.711A/u, G.722, G.723.1,726-32 G.729AB, None.
Second Codec	The second preferential DSP codec: G.711A/u, G.722, G.723.1,726-32 G.729AB, None.
Third Codec	The third preferential DSP codec: G.711A/u, G.722, G.723.1,726-32 G.729AB, None.
Fourth Codec	The forth preferential DSP codec: G.711A/u, G.722, G.723.1,726-32 G.729AB, None.
Fifth Codec	The fifth preferential DSP codec: G.711A/u, G.722, G.723.1,726-32 G.729AB, None.
Sixth codec	The sixth preferential DSP codec: G.711A/u, G.722, G.723.1,726-32 G.729AB, None.
Onhook Time	Specify the least reflection time of Hand down, the default is 200ms.
Default Ring Type	Set up the ring by default.
Handset Output Volume	Specify Output (receiver) Volume grade.
Speakerphone	Specify Speakerphone Volume grade.

volume

---

G729AB Payload Length      Set G729 Payload Length.

---

Tone Standard      Select Tone Standard.

---

G722 Timestamps      160/20ms or 320/20ms is available.

---

G723.1 Bit Rate      5.3 kb/s or 6.3 kb/s is available.

---

Enable VAD      Select it or not to enable or disable VAD. If enable VAD, G729 Payload length could not be set over 20ms.

---

DTMF Payload Type      Set DTMF Payload Type.

---

### 8.3.4.2 FEATURE

In this web page, you can configure Hotline, Call Transfer, Call Waiting, 3 Ways Call, Black List, white list Limit List and so on.

AUDIO	FEATURE	DIAL PLAN	CONTACT	REMOTE CONTACT	WEB DIAL	MCAST
<b>Feature Settings</b>						
DND (Do Not Disturb)	<input type="text" value="Disabled"/>		Ban Outgoing	<input type="checkbox"/>		
Enable Call Transfer	<input checked="" type="checkbox"/>		Enable Call Waiting	<input checked="" type="checkbox"/>		
Semi-Attended Transfer	<input checked="" type="checkbox"/>		Enable 3-way Conference	<input checked="" type="checkbox"/>		
Enable Auto Handdown	<input checked="" type="checkbox"/>		Accept Any Call	<input checked="" type="checkbox"/>		
Auto Handdown Time	<input type="text" value="3"/> second(s)		Enable Call Completion	<input type="checkbox"/>		
Enable Auto Redial	<input type="checkbox"/>		Enable Pre-Dial	<input checked="" type="checkbox"/>		
Auto Redial Interval	<input type="text" value="10"/> (1~180)second(s)		Enable Silent Mode	<input type="checkbox"/>		
Auto Redial Times	<input type="text" value="10"/> (1~100)		Hide DTMF	<input type="text" value="Disabled"/>		
Auto Headset	<input checked="" type="checkbox"/>		Ring From Headset	<input type="checkbox"/>		
Enable Intercom	<input checked="" type="checkbox"/>		Enable Intercom Mute	<input type="checkbox"/>		
Enable Intercom Tone	<input checked="" type="checkbox"/>		Enable Intercom Barge	<input checked="" type="checkbox"/>		
P2P IP Prefix	<input type="text"/>		DND Return Code	<input type="text" value="480(Temporarily Not Available)"/>		
Turn Off Power Light	<input checked="" type="checkbox"/>		Busy Return Code	<input type="text" value="486(Busy Here)"/>		
Emergency Call Number	<input type="text" value="110"/>		Reject Return Code	<input type="text" value="603(Decline)"/>		
Enable Password Dial	<input type="checkbox"/>		Active URI Limit IP	<input type="text"/>		
Password Dial Prefix	<input type="text"/>		Push XML Server	<input type="text"/>		
Password Length	<input type="text" value="0"/> (0~31)		Enable Call Waiting Tone	<input checked="" type="checkbox"/>		
Enable Call History	<input checked="" type="checkbox"/>		Enable Multi Line	<input checked="" type="checkbox"/>		
Enable Default Line	<input checked="" type="checkbox"/>		Enable Auto Switch Line	<input checked="" type="checkbox"/>		
Allow IP Call	<input checked="" type="checkbox"/>		Play Dialing DTMF Tone	<input checked="" type="checkbox"/>		
Play Talking DTMF Tone	<input checked="" type="checkbox"/>					
<input type="button" value="Apply"/>						



**Action URL Settings**

Setup Completed	<input type="text"/>
Registration Success	<input type="text"/>
Registration Disabled	<input type="text"/>
Registration Failed	<input type="text"/>
Off Hook	<input type="text"/>
On Hook	<input type="text"/>
Incoming Call	<input type="text"/>
Outgoing Call	<input type="text"/>
Call Established	<input type="text"/>
Call Terminated	<input type="text"/>
DND Enabled	<input type="text"/>
DND Disabled	<input type="text"/>
Always Forward Enabled	<input type="text"/>
Always Forward Disabled	<input type="text"/>
Busy Forward Enabled	<input type="text"/>
Busy Forward Disabled	<input type="text"/>

No Ans. Forward Enabled	<input type="text"/>
No Ans. Forward Disabled	<input type="text"/>
Transfer Call	<input type="text"/>
Blind Transfer Call	<input type="text"/>
Attended Transfer Call	<input type="text"/>
Hold	<input type="text"/>
Resume	<input type="text"/>
Mute	<input type="text"/>
Unmute	<input type="text"/>
Missed Call	<input type="text"/>
IP Changed	<input type="text"/>
Idle To Busy	<input type="text"/>
Busy To Idle	<input type="text"/>

---

**Block Out Settings**

Block Out

## FEATURE

Field name	explanation
Do Not Disturb	Select DND, the phone will reject any incoming call, the callers will be reminded by busy, but any outgoing call from the phone will work well.
Ban Outgoing	If you select Ban Outgoing to enable it, and you cannot dial out any number.
Enable Call Transfer	Enable Call Transfer by selecting it.
Semi-Attended Transfer	Enable Semi-Attended Transfer by selecting it.

Enable Auto Redial	Enable Auto Redial by selecting it, then the phone reminds whether redial, when the caller is busy or rejects.
Auto Redial interval	Specify the Auto Redial interval.
Auto Redial Times	Specify the Auto Redial interval.
Enable Call Completion	Enable Call Completion by selecting it.
Enable Pre-Dial	Disable this feature, in standby interface next number, will realize the number rules "send out over the time";Enable the feature ,then the number will not be send out over the time.
Enable Call Waiting	Enable Call Waiting by selecting it. Then the phone reminds whether redial, when the caller is busy or rejects. if it's ok and the phone finds out that the caller is idle by sip message, it will reminds whether redial.
Enable 3-way Conference	Enable 3-way conference by selecting it.
Enable Call Waiting Tone	Disdale this function ,you will not hear the tone "beep" when there have multiple incoming calls
Accept Any Call	If select it, the phone will accept the call even if the called number is not belong to the phone.
Enable Auto Hand down	The phone will hang up and return to the idle automatically at hands-free mode.
Auto Hand down Time	Specify Auto Hand down Time, the phone will hang up and return to the idle automatically after Auto Hand down Time at hands-free mode, and play dial tone Auto Hand down Time at handset mode.
Ring From Headset	Enable Ring From Handset by selecting it, the phone plays ring tone from handset.
Enable Intercom	Enable Intercom Mode by selecting it.
Enable Intercom Mute	Enable mute mode during the intercom call.
Enable Intercom Tone	If the incoming call is intercom call, the phone plays the intercom tone.
Enable Intercom Barge	Enable Intercom Barge by selecting it, the phone auto answers the intercom call during a call. If the current call is intercom call, the phone will reject the second intercom call.
Enable	Enable Silent Mode by selecting it, the phone light will red

Silent Mode	blink to remind that there is a missed call instead of playing ring tone.
Turn Off Power Light	Enable Turn Off Power Light by selecting it.
Emergency Call Number	Specify the Emergency Call Number. Despite the keyboard is locked, you can dial the emergency call number.
Enable Password Dial	Enable Password Dial by selecting it, When number entered is beginning with the password prefix, the following N numbers After the password prefix will be hidden as *, N stand for the value which you enter in the Password Length field. For example: you set the password prefix is 3, enter the Password Length is 2, then you enter the number 34567, it will display 3**67 on the phone.
Password Length	Specify the Password length.
DND Return Code	Specify DND Return code.
Busy Return Code	Specify Busy Return Code.
Reject Return Code	Specify Reject Return Code.
Hide DTMF	Specify the hide DTMF mode.
Push XML Server	Specify the Push XML Server, when phone receives request, it will determine whether to display corresponding content on the phone which sent by the specified server or not.
P2P IP Prefix	Set Prefix in peer to peer IP call. For example: what you want to dial is 192.168.1.119, If you define P2P IP Prefix as 192.168.1., you dial only #119 to reach 192.168.1.119. Default is “.”. If there is no “.” Set, it means to disable dialing IP.

**Action URL Settings**

Setup Completed	<input type="text"/>
Registration Success	<input type="text"/>
Registration Disabled	<input type="text"/>
Registration Failed	<input type="text"/>
Off Hook	<input type="text"/>
On Hook	<input type="text"/>
Incoming Call	<input type="text"/>
Outgoing Call	<input type="text"/>
Call Established	<input type="text"/>
Call Terminated	<input type="text"/>
DND Enabled	<input type="text"/>
DND Disabled	<input type="text"/>
Always Forward Enabled	<input type="text"/>
Always Forward Disabled	<input type="text"/>
Busy Forward Enabled	<input type="text"/>
Busy Forward Disabled	<input type="text"/>
No Ans. Forward Enabled	<input type="text"/>
No Ans. Forward Disabled	<input type="text"/>
Transfer Call	<input type="text"/>
Blind Transfer Call	<input type="text"/>
Attended Transfer Call	<input type="text"/>
Hold	<input type="text"/>
Resume	<input type="text"/>
Mute	<input type="text"/>
Unmute	<input type="text"/>
Missed Call	<input type="text"/>
IP Changed	<input type="text"/>
Idle To Busy	<input type="text"/>
Busy To Idle	<input type="text"/>

**Block Out Settings**

Block Out

**Active URI Limit IP** Specify the server IP that remote control phone for corresponding operation.

**Action URL Settings**

**Action URL Settings** Specify the Action URL that Record the operation of phone; send this corresponding information to server, url: <http://InternalServer /FileName.xml?> (Internal Server is server IP. Filename is name of xml that contains the action message).

**Block Out Settings**

**Block out** Set Add/Delete Limit List. Please input the prefix of those phone numbers which you forbid the phone to dial out. For example, if you want to forbid those phones of 001 as prefix to be dialed out, you need input 001 in the blank of limit list, and then you cannot dial out any phone number whose prefix is 001.  
X and are wildcard x means matching any single digit. For example, 4xxx expresses any number with prefix 4 which

length is 4 will be forbidden to dialed out means matching any arbitrary number digit. For example, 6 expresses any number with prefix 6 will be forbidden to dialed out.

---

Notice: Black List and Limit List can record at most 10 items respectively.

---

#### 8.3.4.3 DIAL PLAN

This system supports those dial modes as followings:

- 1) End with "#": dial your desired number, and then press #.
- 2) Fixed Length: the phone will intersect the number according to your specified length.
- 3) Time Out: After you stop dialing and waiting time out, system will send the number collected.
- 4) Press # to Do Blind Transfer: input the number you want to transfer to then press "#" you can transfer the current call to the number.
- 5) Blind Transfer on OnHook : input the number you want to transfer to then hang up handle or press speaker, you can transfer the current call to the number.
- 6) Attend Transfer on OnHook: hang up handle or press speaker you can realize the blind transfer function
- 7) Press the DSS key Blind: Press dss key, the current call will turn out blind.
- 7) User defined: you can customize digital map rules to make dialing more flexible. It is realized by defining the prefix of phone number and number length of dialing.

In order to maintain the end-user pbx secondary dial for dialing call mode. When requested to enter a phone number prefix, the system according to the rules in the closing number configuration rules, re-issue the dial tone, the user continues to enter the number, after the end of the closing number, the phone number will be prefixed and analog secondary dial tone is sent to the back of the numbers together server.

For example:

In the list of rules in the configuration of the closing number 9, xxxxxxxx then when the user dials 9, the system to re-play the dial tone, dial the number the user to continue; dial-up is complete, the phone is actually sent containing 9 9 numbers.

## DIAL PLAN Configuration

Field name	explanation
<b>Basic Setting</b>	
Press "#" to Send	Set Enable/Disable the phone ended with “#” dial.
Dial Fixed Length	Specify the Fixed Length of phone ending with.
Press # to Do Blind Transfer	Enable Blind Transfer On Hook, when executing Blind Transfer End with #, press # after inputting the number that you want to transfer, the phone will transfer the current call to the third party.
Blind Transfer on OnHook	Enable Blind Transfer on On Hook, when executing Blind Transfer, hang up after inputting the number that you want to transfer, the phone will transfer the current call to the third party.
Attend Transfer on OnHook	Enable Attend Transfer on On Hook, when executing Attended Transfer, hang up after the third party answers, the phone will transfer the current call to the third party.

Below is user-defined digital map rule:

[] Specifies a range that will match digit. May be a range, a list of ranges separated by commas, or a list of digits.

\* Match any single digit that is dialed.

. Match any arbitrary number of digits including none.

Tn Indicates an additional time out period before digits are sent of n seconds in length. n is mandatory and can have a value of 0 to 9 seconds.

Tn must be the last 2 characters of a dial plan. If Tn is not specified it is assumed to be T0 by default on all dial plans.

#### Dial Plan Table

Plans:
"[1-8]xxx"
"9xxxxxxx"
"911"
"99T4"
"9911x.T4"

Cause extensions 1000-8999 to be dialed immediately.

Cause 8 digit numbers started with 9 to be dialed immediately.

Cause 911 to be dialed immediately after it is entered.

Cause 99 to be dialed after 4 seconds.

Cause any number started with 9911 to be dialed 4 seconds after dialing ceases.

---

**Notice:** End with "#", Fixed Length, Time out and Digital Map Table can be used simultaneously, System will stop dialing and send number according to your set rules.

---

#### 8.3.4.4 CONTACT

You can input the name, phone number and select ring type for each name here.

AUDIO	FEATURE	DIAL PLAN	CONTACT	REMOTE CONTACT	WEB DIAL	MCAST
-------	---------	-----------	---------	----------------	----------	-------

**Phonebook Table**

Group:  [Hangup](#)

Index	Name	Office Number	Mobile Number	Other Number	Ring Type	Group	<input type="checkbox"/>
Page: <input type="text" value="1"/>	<input type="text" value="Pre"/>	<input type="text" value="Next"/>	<input type="text" value="friend"/>	<input type="text" value="Add"/>	<input type="text" value="Add to Blacklist"/>	<input type="text" value="Delete"/>	<input type="text" value="Delete All"/>

---

**Add Contact**

Name:

Office Number:

Mobile Number:

Other Number:

Ring Type:

Line:

Line:

Line:

Group Setting:

friend  
home  
work  
business  
classmate

---

**Import Contact List**

Select File:   (\*.xml,\*.vcf,\*.csv)

---

**Export Contact List**

---

**Group Option**

Group:

Name:

Ring Type:

---

**Blacklist Settings**

Blacklist Item:

Type:

Value:

Line:

## Contact

Field name	explanation
<b>Phonebook Table</b>	
Name	Shows the name corresponding to the phone number.
Shows the detail of current phonebook.	
Notice: the maximum capability of the phonebook is 500 items, you can select many or a contact to add to group and add to blacklist, and delete many or a contact, and delete all contacts.	
<b>Add Contact List</b>	
Name	Specify the name corresponding to the phone number.



Office Number	Specify the office number.
Mobile Number	Specify the mobile number.
Other Number	Specify the other number.
Ring Type	Specify the ring type for the phone number.
Line	Specify the sip line for the each number.
Group setting	Select the group from the unselected group to selected list for the contact; you can select many groups for the contact.

Notice: the add button for adding a new contact, the modify button for modifying the added contact, the clear all button for clear all input information of the contact.

### Group Option

Group	Select the added groups then modify or delete and so on.
Name	Input the name of the group, then click the add button, you can add a new group.
Ring Type	Specify the ring type for the group as adding a new group.

### Blacklist Settings

Type	Select the blacklist type, you can select number or prefix of number.
Value	Input number or prefix of number.
Line	Select the sip line.

Notice: the add button for adding a new blacklist, the delete button for deleting one item, the delete all button for deleting all items.

If user does not want to answer some phone calls, add these phone numbers to the Black List, and these calls will be rejected x and are wildcard x means matching any single digit. For example, 4xxx expresses any number with prefix 4 which length is 4 will be forbidden to be responded.

DOT (.) means matching any arbitrary number digit. For example, 6. expresses any number with prefix 6 will be forbidden to be responded. If user wants to allow a number or a series of number incoming, he may add the number(s) to the list as the white list rule. The configuration rule is -number, for example, -123456, or -1234xx.

Black List
-4119
.

Means any incoming number is forbidden except for 4119

Note: End with DOT (.) when set up the white list.

### 8.3.4.5 REMOTE CONTACT

AUDIO	FEATURE	DIAL PLAN	CONTACT	REMOTE CONTACT	WEB DIAL	MCAST
-------	---------	-----------	---------	----------------	----------	-------

**Remote Phonebook Settings**

Index	Phonebook Name	Server URL	SIP Line	User	Password
1	<input type="text"/>	<input type="text"/>	Auto ▾	<input type="text"/>	<input type="text"/>
2	<input type="text"/>	<input type="text"/>	Auto ▾	<input type="text"/>	<input type="text"/>
3	<input type="text"/>	<input type="text"/>	Auto ▾	<input type="text"/>	<input type="text"/>
4	<input type="text"/>	<input type="text"/>	Auto ▾	<input type="text"/>	<input type="text"/>

**LDAP Settings**

LDAP  ▾

Display Title	<input type="text"/>	Version	Version 3 ▾
Server Address	<input type="text"/>	Server Port	389
Authentication	None ▾	Line	AUTO ▾
Username	<input type="text"/>	Password	<input type="text"/>
Search Base	<input type="text"/>	Enable Calling Search	<input type="checkbox"/>
Telephone	telephoneNumber	Mobile	mobile
Other	home	Display Name	cn

You need to match a XML Phonebook address and you can directly access to the corresponding remote phonebook on the phone.

For example: Set the Phonebook Name as fanvil, Server URL is tftp://192.168.1.3/admin/phonebook/index.xml.

Or Set the Phonebook Name as ldap, Server URL is ldap://192.168.1.3/dc=winline,dc=com.

#### Remote Phonebook Setting

Phonebook Name	Custom the phonebook name displayed on the phone.
Server URL	Specify the server url of the remote phonebook.
SIP Line	Specify the sip line for the remote phonebook.
Authentication	Specify the authentication mode for remote phonebook.
User/password	Input the authentication username and password.

### 8.3.4.6 WEB DIAL

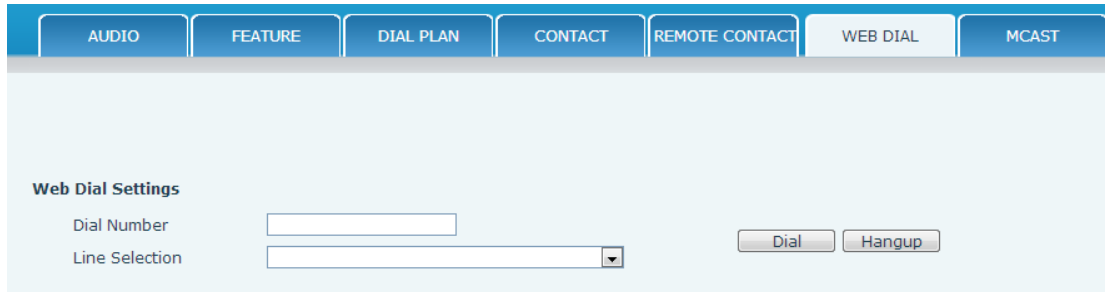

You can make a call through the WEB DIAL, enter the Dial Number then press Dial, if you want to finish the talk, press Hang-up.

### 8.3.4.7 MCAST

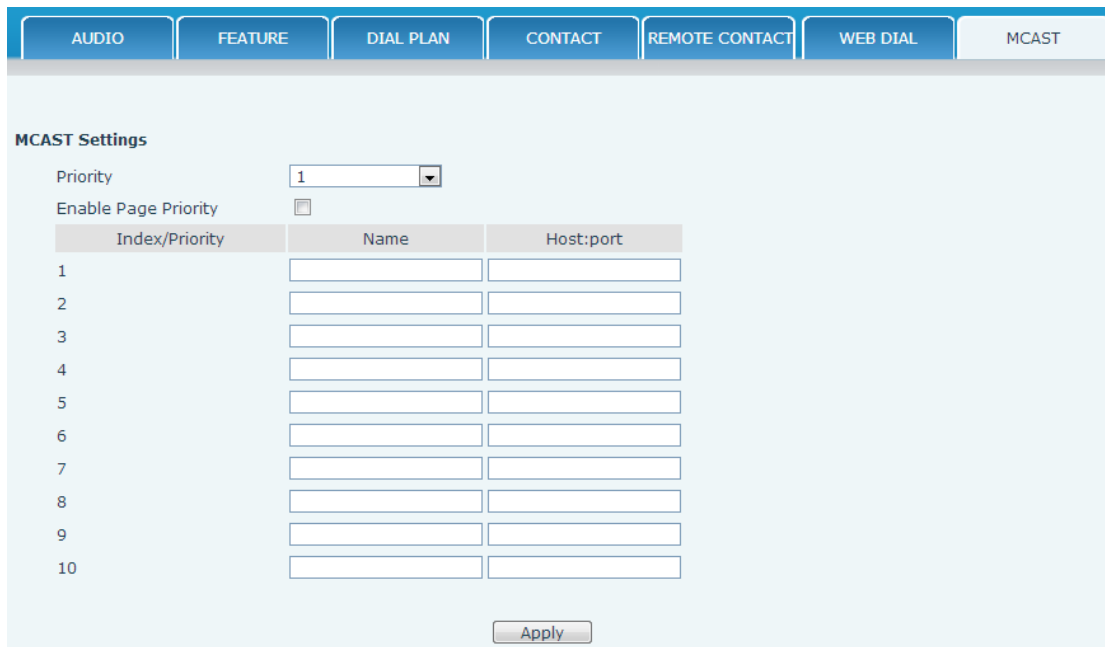

Index/Priority	Name	Host:port
1		
2		
3		
4		
5		
6		
7		
8		
9		
10		

Use the multicast function to send notice to every member of the multicast is simple and easy. By setting the multicast key on your phone, you can send multicast RTP flow to the pre-configured multicast address. By listening multicast address is configured on the phone, listen and play the multicast address to send the RTP stream.

#### Send multicast setting

On the phone web page,function key-function key,set a function key, as shown

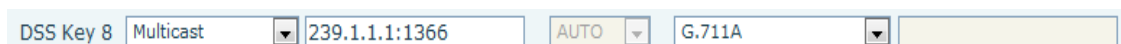

Value format IP:Port, the IP address of multicast is range from 224.0.0.0 to 239.255.255.255, port is greater than 1024

If multicast codec is G722, the LCD screen will displays "HD", which means the phone is sending high-definition voice stream

Operate steps:

1、 When the phone is idle, press multicast key

Multicast RTP stream is sended to pre-configured multicast address (IP: Port). The phone which listens to multicast address in the local network can receive the RTP stream. Multicast functionkey LED lights yellow.

LCD screen displays the following:



2、 Press the hold softkey to hold the current multicast session

3、 Press the end softkey again or multicast functionkey, multicast session can be stopped

Notice: RTP stream is one side, that is from a sender to a receiver. when the phone initiates a multicast RTP session in a call, the current call is on hold.

### **Receive multicast setting**

You can set up the phone monitoring 10 different multicast addresses to receive these multicast RTP stream.

You have two method to receive RTP stream of multicast that can be set up through the web page: Enable priorities of normal calls and Enable page Priority:

Enable priorities of normal call by select it, if the incoming RTP stream priority of multicast lower than the priority of current for normal calls, the phone will ignore the RTP stream of multicast. If the incoming RTP stream priority of multicast higher than the priority of current for normal calls, the phone will receive the RTP stream of multicast, and hold the current call.

Disabled priorities of normal call by select disable, the phone will ignore all local network RTP stream of multicast.

Options as follows:

1-10:the priority defined for normal calls,1 the highest level,10 the lowest level

Disabled: Ignore all RTP stream of multicast

### Enable Page Priority

Page priority determines the phone how to handle the newly received multicast RTP stream when in a multicast session. Enabled page priority, the phone will automatically ignore the low priority multicast RTP stream and receive the high priority multicast RTP stream and hold the current multicast session; If not enabled, the phone will automatically ignore all incoming multicast RTP stream.

Web page is set as follows:

**MCAST Settings**

Priority

Enable Page Priority

Index/Priority	Name	Host:port
1	ss	239.1.1.1:1366
2	ee	239.1.1.1:1367

Now multicast ss has higher priority than multicast ee, the highest priority is for normal calls

Notice: When a multicast session begins, multicast sender and receiver will beep

## 8.3.5 FUNCTION KEY

### 8.3.5.1 SOFTKEY

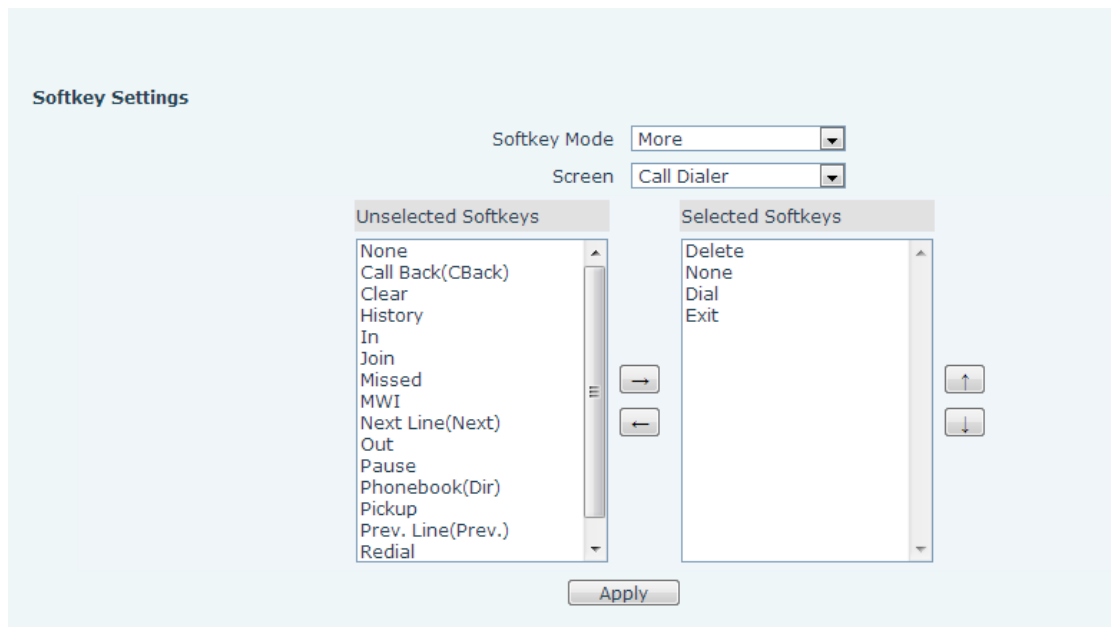

## SOFTKEY

You can configure different functions in different screens for every softkey.

## 8.3.6 Maintenance

### 8.3.6.1 Auto Provision

AUTO PROVISION	SYSLOG	CONFIG	UPDATE	ACCESS	REBOOT
----------------	--------	--------	--------	--------	--------

**Auto Provision Settings**

Current Config Version	2.0002
Common Config Version	2.0002
CPE Serial Number	00100400XH020010000000010e597052
User	<input type="text" value="user"/>
Password	<input type="password" value="••••"/>
Config Encryption Key	<input type="text"/>
Common Config Encryption Key	<input type="text"/>
Save Auto Provision Information	<input type="checkbox"/>

---

**DHCP Option Settings >>**

---

**Plug and Play (PnP) Settings >>**

---

**Phone Flash Settings >>**

---

**TR069 Settings >>**

---

**DHCP Option Settings >>**

DHCP Option Setting	<input type="text" value="DHCP Option 66"/>
Custom DHCP Option	<input type="text" value="66"/> (128~254)

---

**Plug and Play (PnP) Settings >>**

Enable PnP	<input checked="" type="checkbox"/>
PnP Server	<input type="text" value="224.0.1.75"/>
PnP Port	<input type="text" value="5060"/>
PnP Transport	<input type="text" value="UDP"/>
PnP Interval	<input type="text" value="1"/> hour(s)

---

**Phone Flash Settings >>**

Server Address	<input type="text" value="0.0.0.0"/>
Config File Name	<input type="text"/>
Protocol Type	<input type="text" value="FTP"/>
Update Interval	<input type="text" value="1"/> hour(s)
Update Mode	<input type="text" value="Disabled"/>

Fanvil endpoint supports PnP and DHCP and Phone Flash to obtain the parameters. The PnP and DHCP and Phone Flash are all deployed, endpoint will go by the following process to try to obtain the server address and other parameters, when it boots up:

DHCP option → PnP server → Phone Flash

## Auto Provision

Field name	explanation
<b>Auto Update Setting</b>	
Current Config Version	Show the current config file's version. If the version of the configuration downloaded is higher than the version of the running configurations, the auto provision would upgrade, or stop here. If the endpoints confirm the configuration by Digest method, the endpoints wouldn't upgrade configuration unless the configuration in the server is different with the running configuration.
Common Config Version	Show the common config file's version. If the configuration downloaded and the running configurations are the same, the auto provision would stop here. If the endpoints confirm the configuration by Digest method, the endpoints wouldn't upgrade configuration unless the configuration in the server is different with the running configuration.
CPE Serial Number	Show CPE Serial Number.
User	Specify FTP/HTTP/HTTPS server Username. System will use anonymous if username keep blank.
Password	Specify FTP/HTTP/HTTPS server Password.
Config Encrypt Key	Input the Encrypt Key, if the configuration file is encrypted.
Common Config Encrypt Key	Input the Common Encrypt Key, if the Common Configuration file is encrypted.
Save Autoprovision Information	Save the username and password authentication message of http/https/ftp and input ID message in the phone until the url in the server changes.
<b>DHCP Option Setting</b>	
DHCP Option Setting	Specify DHCP Option. DHCP option supports DHCP custom option and DHCP option 66 and DHCP option 43 to obtain the parameters. You could choose one method among them; the default is DHCP option disable.
Custom DHCP Option	A valid Custom DHCP Option is from 128 to 254. The Custom DHCP Option must be in accordance with the one defined in the DHCP server.



## Plug and Play

Enable PnP	Enable PnP by selecting it, then the phone will send SIP SUBSCRIBE messages to a multicast address when it boots up. Any SIP server understanding that message will reply with a SIP NOTIFY message containing the Auto Provisioning Server URL where the phones can request their configuration.
PnP Server	Specify the PnP Server.
PnP Port	Specify the PnP Server.
PnP Transport	Specify the PnP Transfer protocol.
PnP Interval	Specify the Interval time, unit is hour.

## Phone Flash

Server Address	Set FTP/TFTP/HTTP server IP address for auto update. The address can be IP address or Domain name with subdirectory.
Config File Name	Set configuration file's name which need to update. System will use MAC as config file name if config file name keep blank. For example, 000102030405.
Protocol Type	Specify the Protocol type FTP, TFTP or HTTP.
Update Interval	Specify update interval time, unit is hour.
Update Mode	Different update modes: 1. Disable: means no update. 2. Update after reboot: means update after reboot. 3. Update at time interval: means periodic update.

## TR069 Settings

Enable TR069	Enable TR069 by selecting it.
ACS Server Type	Specify the ACS Server Type.
ACS Server URL	Specify the ACS Server URL.
ACS User	Specify ACS User.
ACS Password	Specify ACS Password.
TR069 Auto Login	Enable TR069 Auto Login by selecting it.
"Inform" Sending Period	Specify the "inform" Sending Period, unit is second.

### 8.3.6.2 SYSLOG

Syslog is a protocol which is used to record the log messages with client/server mechanism. Syslog server receives the messages from clients, and classifies them based on priority and type. Then these messages will be written into log by some rules which administrator can configure. This is a better way for log management.

8 levels in debug information:

Level 0---emergency: This is highest default debug info level. Your system cannot work.

Level 1---alert: Your system has deadly problem.

Level 2---critical: Your system has serious problem.

Level 3---error: The error will affect your system working.

Level 4---warning: There are some potential dangers. But your system can work.

Level 5---notice: Your system works well in special condition, but you need to check its working environment and parameter.

Level 6---info: the daily debugging info.

Level 7---debug: the lowest debug info Professional debugging info from R&D person.

At present, the lowest level of debug information is info; debug level only can be displayed on telnet.

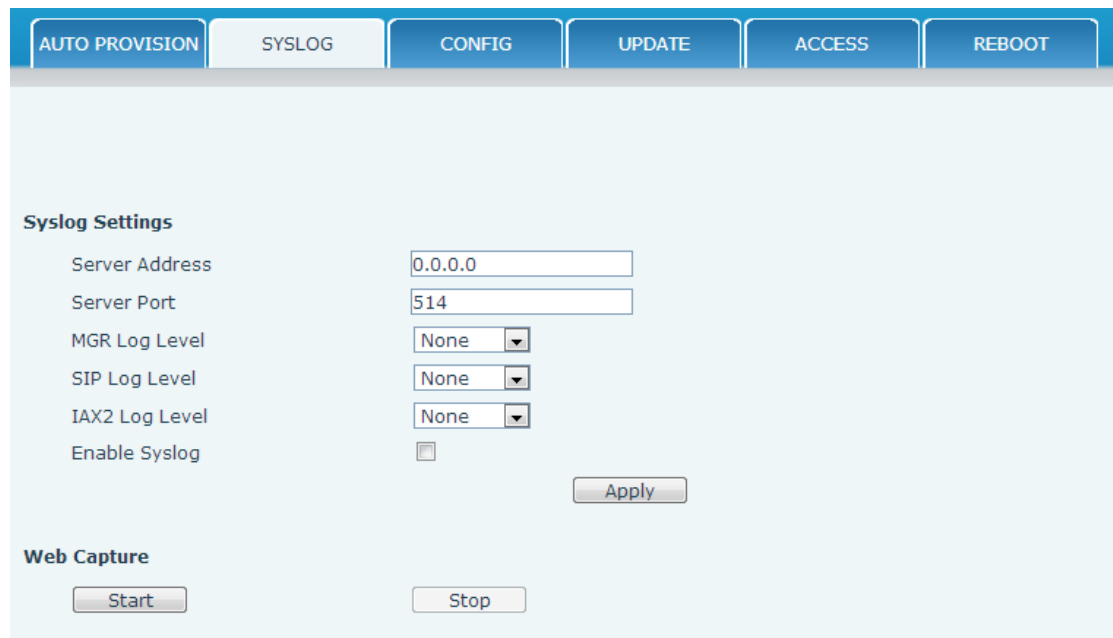

## Syslog Configuration

Field name	explanation
<b>Syslog Setting</b>	
Server Address	Set Syslog server IP address.
Server Port	Set Syslog server port.
MGR Log Level	Set the level of MGR log.
SIP Log Level	Set the level of SIP log.
IAX2 Log Level	Set the level of IAX2 log.
Enable Syslog	Select it or not to enable or disable syslog.
<b>Web Capture</b>	
Start	Click the start button when you need capture the WAN packet stream of the phone, then open or save the file as the interface.

Stop

Click the end button to stop capturing the packet stream.

---

### 8.3.6.3 CONFIG

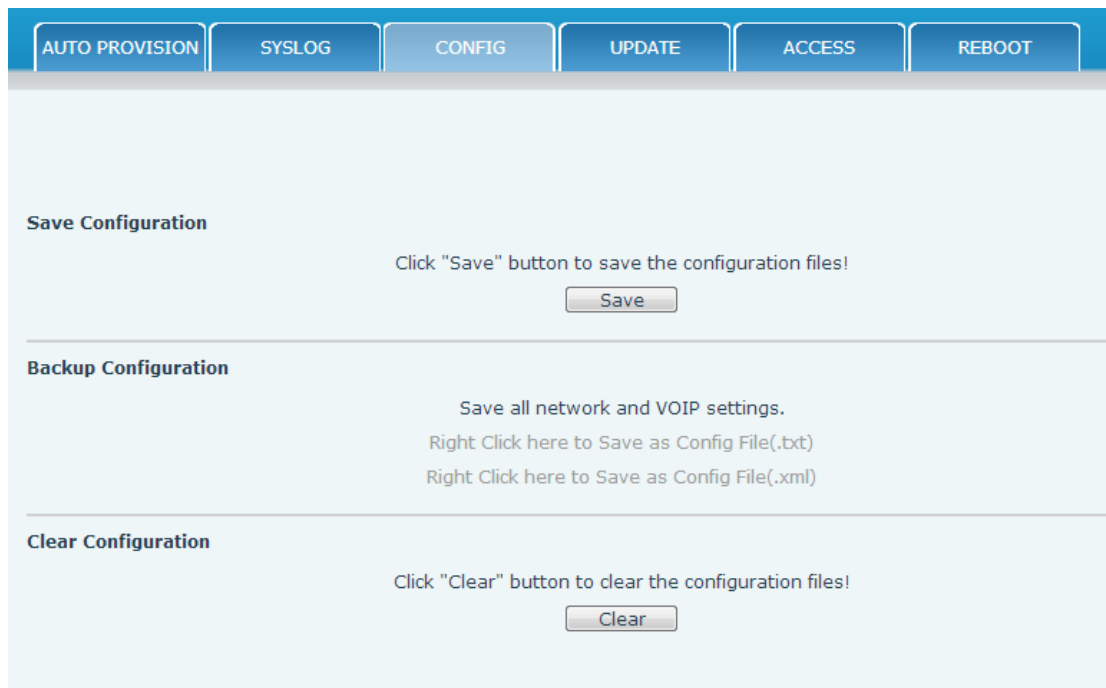

## Config Setting

Field name	Explanation
Save Configuration	You can save all changes of configurations. Click the Save button, all changes of configuration will be saved, and be effective immediately.
Backup Configuration	Right clicks on "Right click here..." and select "Save Target As config File(.txt)" then you will save the config file in .txt format, or select "Save Target As config File(.xml)" then you will save the config file in .xml format.
Clear Configuration	User can restore factory default configuration and reboot the phone. If you login as Admin, the phone will reset all configurations and restore factory default; if you login as Guest, the phone will reset all configurations except for VoIP accounts (SIP1-2 and IAX2) and version number.

---

### 8.3.6.4 UPDATE

You can update your configuration with your config file in this web page.

The screenshot shows a web interface with a top navigation bar containing buttons for AUTO PROVISION, SYSLOG, CONFIG, UPDATE (selected), ACCESS, and REBOOT. Below the navigation bar, there are several sections:

- Web Update:** A 'Select File:' input field, a 'Browse' button, a file type filter '(\*.z,\*.txt,\*.xml,\*.au,\*.vcf,\*.csv,\*.wav)', and an 'Update' button.
- TFTP/FTP Update:** Fields for 'Server Address', 'User', 'Password', and 'File Name'. A 'Type' dropdown menu is set to 'Application Update', and a 'Protocol' dropdown menu is set to 'FTP'. An 'Apply' button is located to the right.
- Update Logo File:** A 'Select File:' input field, a 'Browse' button, and an 'Update' button.
- Delete Logo File:** A 'Select File:' dropdown menu showing 'screensaver.txt' and a 'Delete' button.
- Logo File:** A table listing the current logo file: 'screensaver.txt' with a size of '(5779 Bytes)'.

## Update

Field name	Explanation
<b>Web Update</b>	
Web Update	Click the browse button, find out the config file saved before or provided by manufacturer, download it to the phone directly, press “Update” to save. You can also update downloaded update file, logo picture, ring, mmiset file by web.
<b>TFTP/FTP Update</b>	
Server Address	Set the FTP/TFTP server address for download/upload. The address can be IP address or Domain name with subdirectory.
User	Set the FTP server Username for download/upload.
Password	Set the FTP server password for download/upload.
File name	Set the name of update file or config file. The default name is the MAC of the phone, such as 000102030405.
<b>Notice:</b> You can modify the exported config file. And you can also download config file which includes several modules that need to be	

---

imported. For example, you can download a config file just keep with SIP module. After reboot, other modules of system still use previous setting and are not lost.

---

Type	Action type that system want to execute: 1. Application update: download system update file. 2. Config file export: Upload the config file to FTP/TFTP server, name and save it. 3. Config file import: Download the config file to phone from FTP/TFTP server. The configuration will be effective after the phone is reset. 4. Phone book export (.vcf): Upload the phonebook file to FTP/TFTP server, name and save it. 5. PhoneBook import (.vcf): Download the phonebook file to phone from FTP/TFTP server.
------	--

---

Protocol	Select FTP/TFTP server.
----------	-------------------------

---

#### **Update Logo File**

---

Select File	Specify the url of the logo file.
-------------	-----------------------------------

---

#### **Delete Logo File**

---

Select File	Select the logo that you want to delete.
-------------	--

---

#### **Logo File**

---

Logo File	Show the logo file.
-----------	---------------------

---

#### **8.3.6.5 ACCESS**

You can add or delete user account, and change the authority of each user account in this web page.

AUTO PROVISION
SYSLOG
CONFIG
UPDATE
ACCESS
REBOOT

---

**LCD Menu Password Settings**

Menu Password  Apply

---

**Keyboard Lock Settings**

PIN to Lock

Keyboard Password  Apply

Enable Keyboard Lock

---

**User Settings**

User	User Level
admin	Root
guest	General

---

**Add User**

User

Password

Confirm

User Level Root ▼ Apply

---

**User Management**

admin ▼ Delete Modify

## Access Configuration

Field name	explanation
Keyboard Password	Set the password for entering the setting menu of the phone by the phone's key board. The password is digit.

User Settings	
User	User Level
admin	Root
guest	General

This table shows the current user existed.

User	Set account user name.
User Level	Set user level, Root user has the right to modify configuration, General can only read.
Password	Set the password.
Confirm	Confirm the password.
Select the account and click the <b>Modify</b> to modify the selected account, and click the <b>Delete</b> to delete the selected account.	
General user only can add the user whose level is General.	

### 8.3.6.6 REBOOT

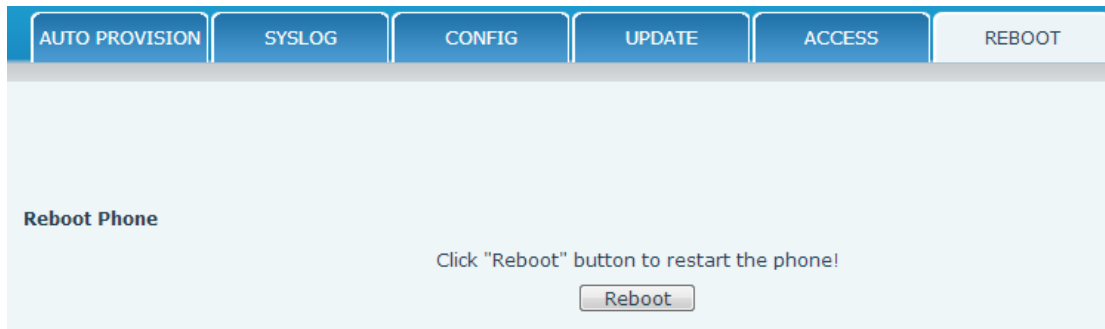

If you modified some configurations which need the phone's reboot to be effective, you need click the Reboot, then the phone will reboot immediately.

**Notice:** Before reboot, you need confirm that you have saved all configurations.

## 8.3.7 SECURITY

### 8.3.7.1 WEB FILTER

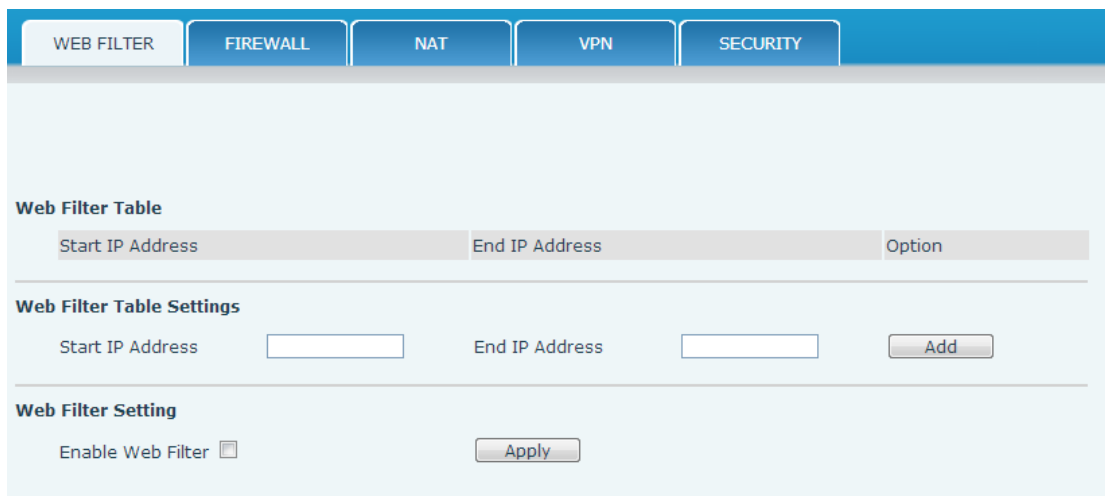

## WEB Filter

---

User could make some device own IP, which is pre-specified, access to the MMI of the phone to config and manage the phone.

---

Field name	explanation
------------	-------------

---

Web Filter Table Settings:

---

Add or delete the IP address segments that access to the phone.

Set initial IP address in the Start IP column, Set end IP address in the End IP column, and click Add to add this IP segment. You can also click Delete to delete the selected IP segment.

---

---

Web Filter setting    Select it or not to enable or disable Web Filter. Click **Apply** to make it effective.

---

**Notice:** Do not set your visiting IP outside the Web filter range, otherwise, you cannot logon through the web.

---

### 8.3.7.2 FIREWALL

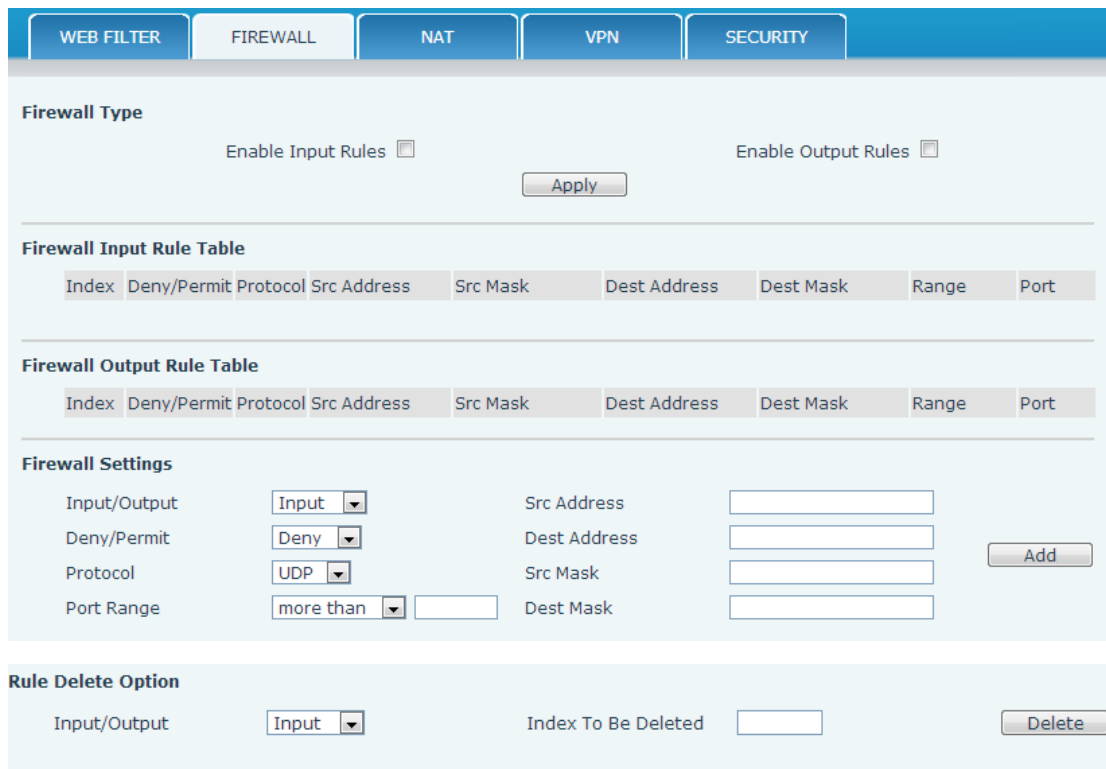

**Firewall Type**

Enable Input Rules       Enable Output Rules

Apply

---

**Firewall Input Rule Table**

Index	Deny/Permit	Protocol	Src Address	Src Mask	Dest Address	Dest Mask	Range	Port
-------	-------------	----------	-------------	----------	--------------	-----------	-------	------

---

**Firewall Output Rule Table**

Index	Deny/Permit	Protocol	Src Address	Src Mask	Dest Address	Dest Mask	Range	Port
-------	-------------	----------	-------------	----------	--------------	-----------	-------	------

---

**Firewall Settings**

Input/Output:       Src Address:

Deny/Permit:       Dest Address:

Protocol:       Src Mask:

Port Range:        Dest Mask:

Add

---

**Rule Delete Option**

Input/Output:       Index To Be Deleted:

Delete

## Firewall Configuration

---

In this web interface, you can set up firewall to prevent unauthorized Internet users from accessing private networks connected to the Internet (input rule), or prevent unauthorized private network devices from accessing the Internet (output rule).

Firewall supports two types of rules: input access rule and output access rule. Each type supports at most 10 items.

Through this web page, you could set up and enable/disable firewall with input/output rules. System could prevent unauthorized access, or access other networks set in rules for security. Firewall, is also called access list, is a simple implementation of a Cisco-like access list (firewall). It supports two access lists: one for filtering input packets, and the other for filtering output packets. Each kind of list could be added 10 items.

We will give you an instance for your reference.

---

Field name	explanation
Enable Input Rules	Select it to Enable Input Rules.

---



Enable Output Rules	Select it to Enable Output Rules.
Input / Output	Specify current adding rule by selecting input rule or output rule.
Deny/Permit	Specify current adding rule by selecting Deny rule or Permit rule.
Protocol	Filter protocol type. You can select TCP, UDP, ICMP, or IP.
Port Range	Set the filter Port range.
Src Address	Set source address. It can be single IP address, network address, complete address 0.0.0.0, or network address similar to *.*.*.0.
Des Address	Set the destination address. It can be IP address, network address, complete address 0.0.0.0, or network address similar to *.*.*.*.
Src Mask	Set the source address' mask. For example, 255.255.255.255 means just point to one host; 255.255.255.0 means point to a network which network ID is C type.
Dest Mask	Set the destination address' mask. For example, 255.255.255.255 means just point to one host; 255.255.255.0 means point to a network which network ID is C type.

Click the **Add** button if you want to add a new output rule. Then enable out access, and click the Apply button. So when devices execute to ping 192.168.1.118, system will deny the request to send icmp request to 192.168.1.118 for the out access rule. But if devices ping other devices which network ID is 192.168.1.0, it will be normal.

Click the **Delete** button to delete the selected rule.

### 8.3.7.3 NAT

NAT is abbreviated from Net Address Translation; it's a protocol responsible for IP address translation. In other word, it is responsible for transforming IP and port of private network to public, also is the IP address mapping which we usually say.

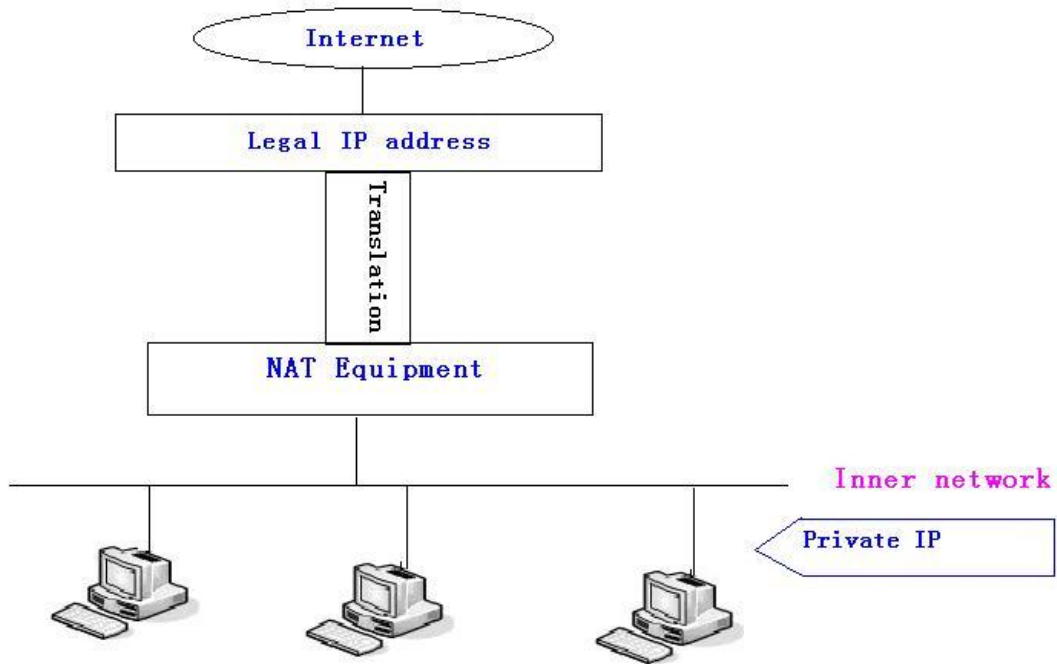

**DMZ config:**

In order to make some intranet equipment support better service for extranet, and make internal network security more effectively, these equipment open to extranet need be separated from the other equipment not open to extranet by the corresponding isolation method according to different demands. We can provide the different security level protection in terms of the different resources by building a DMZ region which can provide the network level protection for the equipment environment, reduce the risk which is caused by providing service to distrust customer, and is the best position to put public information

The following chart describes the network access control of DMZ.

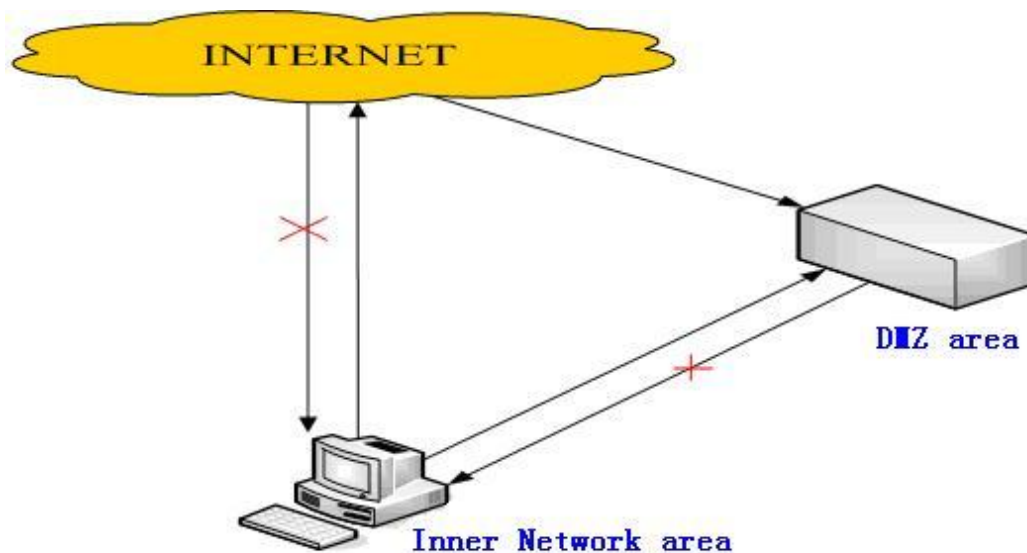

WEB FILTER FIREWALL NAT VPN SECURITY

**Application Layer Gateway (ALG) Settings**

IPSec ALG  FTP ALG  PPTP ALG

Apply

**Network Address Translation (NAT) Table**

Inside IP Address	Inside TCP Port	Outside TCP Port
Inside IP Address	Inside UDP Port	Outside UDP Port

**NAT Table Option**

Transfer Type:

Outside Port:

Inside IP Address:

Inside Port:

Add Delete

DMZ Settings

## NAT Configuration

Field name	explanation
IPSec ALG	It is an encryption technology. Select it to enable IPSec ALG, the default is enabled.
FTP ALG	FTP is a service of connection layer which can transform intranet IP into extranet IP when intranet IP is sending out packet. Select it to enable FTP ALG, the default is enabled.
PPTP ALG	Select it enable PPTP ALG, the default is enabled.
Shows the NAT TCP mapping table	

Shows the NAT UDP mapping table

---

Transfer Type	Select the NAT mapping protocol style, TCP or UDP
---------------	---

---

Inside IP	Set the IP address of device which is connected to LAN interface to do NAT mapping.
-----------	---

---

Inside Port	Set the LAN port of the NAT mapping
-------------	-------------------------------------

---

Outside Port	Set the WAN port of the NAT mapping
--------------	-------------------------------------

---

**Notice:** After finish setting, click the Add button to add new mapping table; click the Delete button to delete the selected mapping table.

---

Shows the outside WAN port IP address and the inside LAN port IP address.

---

**Notice:** 10M/100M adaptive means the network card, and other equipment physical consultations speed, testing speed under bridge mode near to 100M, in order to ensure the quality of voice and communications real-time performance, we made some sacrifices of NAT under the transmission performance. Transmit with full capability only when system is idle, so cannot guarantee that the transmission speed reach to 100M.

---

#### 8.3.7.4 VPN

This web page provides us a safe connect mode by which we can make remote access to enterprise inner network from public network. That is to say, you can set it to connect public networks in different areas into inner network via a special tunnel.

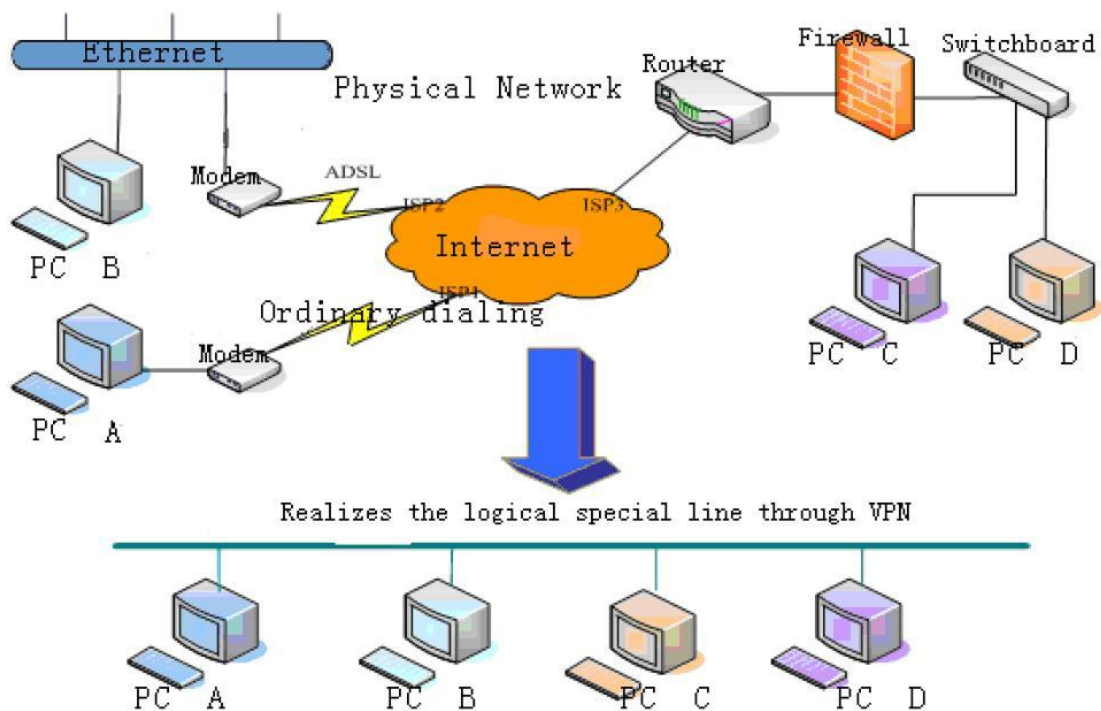

[WEB FILTER](#)
[FIREWALL](#)
[NAT](#)
[VPN](#)
[SECURITY](#)

---

**Virtual Private Network (VPN) Status**

IP Address: 0.0.0.0

---

**VPN Mode**

Enable VPN

L2TP  OpenVPN

---

**Layer 2 Tunneling Protocol (L2TP)**

VPN Server Address:  VPN User:

VPN Password:

## VPN Configuration

Field name	explanation
VPN IP	Shows the current VPN IP address.
Select L2TP. You can choose only one for current state. After you select it, you'd better save configuration and reboot your phone.	
Enable VPN	Select it or not to enable or disable VPN.
VPN Server Address	Set VPN L2TP Server IP address.
VPN User	Set User Name access to VPN L2TP Server.
VPN Password	Set Password access to VPN L2TP Server.

### 8.3.7.5 SECURITY

[WEB FILTER](#)
[FIREWALL](#)
[NAT](#)
[VPN](#)
[SECURITY](#)

---

**Update Security File**

Select Security File:

---

**Delete Security File**

Select Security File:

---

**SIP TLS Files**

---

**HTTPS Files**

---

**OpenVPN Files**

## Security

Field name	explanation
<b>Update Security File</b>	
Select Security File	Select the security file you want to update, then click Update button to update.
<b>Delete Security File</b>	
Select Security File	Select the security file you want to delete, then click Delete button to update.
SIP TLS File	Show SIP TLS authentication certification file.
HTTPS File	Show HTTPS authentication certification file.
Open VPN Files	Show Open VPN File authentication certification file.

### 8.3.8 LOGOUT

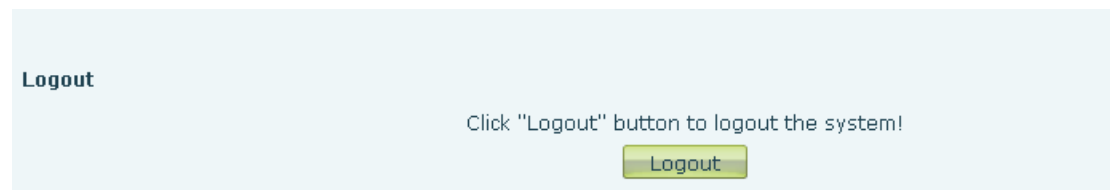

Click **Logout**, and you will exit web page. If you want to enter it next time, you need input user name and password again.

## 9 Appendix

### 9.1.1 Specification Hardware

Item	F52(P)	
Adapter (Input / Output)	Input: 100-240V Output: 5V 1A	
port	WAN	10/100Base- T RJ-45 1 PORT
	LAN	10/100Base- T RJ-45 1 PORT
Power Consumption	Idle: 2.5W/Active: 2.8W	
LCD Size	128x48 62 x 22mm	
Operation Temperature	0~40℃	
Relative Humidity	10~65%	
CPU	Broadcom VoIP chipset	
SDRAM	16MB	
Flash	4MB	
Dimension(L x W x H)	155×185×130mm	
Weight	0.84kg	

### 9.1.2 Voice features

- SIP supports 2 SIP servers
- Support SIP 2.0 (RFC3261) and correlative RFCs
- Support IAX2
- Support multiple call queuing
- Support IAX2 line key to call
- Codec: G.711A/u, G.723.1, G.729a/b, G.722.1, G.726
- Support HD voice
- Echo cancellation: G.168 Compliance in LEC, additional acoustic echo cancellation(AEC) can reach 96ms max filter length in hands-free mode
- Support Voice Gain Setting, VAD, CNG
- Support full duplex hands-free
- SIP support SIP domain, SIP authentication(none basic, MD5), DNS name of server, Peer to Peer/ IP call

- Support DTMF type: SIP info, DTMF Relay, RFC2833
- Support 9 systems ringtones and three user-defined ringtones
- Soft keys programmable
- SIP application: support Call forward / transfer (blind transfer / attended transfer / Ringing Transfer) / Call hold / call waiting / conference call / paging and intercom / call park / then grab / interpolation / Automatic Callback / Click call / auto secondary dial /
- Flexible call control functions: flexible dialing, support hotline number, calling reject, reject blacklist, certification calls, white list barring, do not disturb, speakerphone automatic answer, caller ID, anonymous calls, outgoing calls etc.
- Support phonebook 500 records, Incoming calls / outgoing calls / missed calls. Each supports 300 records.
- Support SMS
- Support MWI
- Support XML phonebook/browser
- Support Speed dial
- Support SRTP
- Code synchronization via IP PBX/IMS
- Support click to dial via web phone book
- Voice codec setting for each SIP line
- Customized lcd logo
- Headset, speakerphone Ringing Selection
- Ringing tone custom configuration parameters
- Group listening

### 9.1.3 Network features













- WAN/LAN: support bridge and router model
- Support basic NAT and NAT
- Support PPPoE for xDSL
- Support VLAN (optional: voice vlan/ data vlan)
- NAT Penetrate, Stun Penetrate
- Support DMZ
- Support VPN (L2TP/OPEN VPN) function
- Wan Port supports main DNS and secondary DNS server can select dynamically to get DNS in DHCP mode or statically set DNS address.
- Support DHCP client on WAN
- Support DHCP server on LAN
- QoS with DiffServ
- Network tools in telnet server: including ping, trace route, telnet client



## 9.1.4 Maintenance and management

- Upgrade firmware through POST mode
- Web ,telnet and keypad management
- Management with different account right
- LCD and WEB configuration can be modified into requested language, and support multi-language dynamically shifted
- Upgrade firmware through HTTP, FTP or TFTP Telnet remote management/ upload/download setting file
- Support Syslog
- Support Auto Provisioning (upgrade firmware or configuration file)

## ■ 9.2 Digit-character map table

Keypad	Character	Keypad	Character
	1 @		7 P Q R S p q r s
	2 A B C a b c		8 T U V t u v
	3 D E F d e f		9 W X Y Z w x y z
	4 G H I g h i		*./
	5 J K L j k l		0
	6 M N O m n o		#/SEND