

1) Product acquired for use in: (Check one)

- 1 Home/home office
 2 A call center
 3 An office outside the home
 4 Other _____

2) How many people are employed at the primary work location/business address of the user?

- 1 1-19 3 100-249 5 500-999
 2 20-99 4 250-499 6 1,000+

3) Approximately how many hours per day does the user spend on the telephone for:

Work:

- 1 0-1 hr 3 4-5 hrs 5 8+ hrs
 2 2-3 hrs 4 6-7 hrs

Personal:

- 1 0-1 hr 3 4-5 hrs 5 8+ hrs
 2 2-3 hrs 4 6-7 hrs

4) Will this product be used primarily for: (Check one)

- 1 Business use 3 or both
 2 Personal use

5) Please indicate the age and gender of the primary user (for classification purposes only):

Age:

- 1 Under 18 3 40-49
 2 18-39 4 50 & over

Gender:

- 1 Male 2 Female

6) Are you the primary user of this product?

- 1 Yes 2 No

7) Plantronics or our affiliates may choose to contact you to request feedback or offer you product information on products or services we think may be of interest to you. Please specify if you prefer **not** to be contacted (check all that apply).

- 1 By email 2 By mail 3 By telephone
 4 Do not contact me
 5 Do not allow your affiliates to contact me

*Thank you for filling out your owner registration. Please tear off at perforation below.
Fold to show Plantronics' address. Remove strip or moisten glue, seal and mail.*

Printed in the U.S.A. 69047-01 (11•04)

© 2000–2004 Plantronics, Inc. All rights reserved.
Plantronics, the logo design, Plantronics and the logo
design combined are trademarks or registered trade-
marks of Plantronics, Inc.

U.S. Patent 5210791, D394,437 and D403,327;
Finland 20183 and 20184;
GB Regd.Des.No. 2073246 and 2073247;
Germany M 98 02 622.4;
Sweden 64 176 and 64 177;
and Patents Pending

345 Encinal Street
Santa Cruz, CA 95060
800.544.4660

www.plantronics.com

 **PLANTRONICS**
World Leader in Communications Headsets

Headset Telephone Single Line

Model T10

User Guide

 **PLANTRONICS**[®]
World Leader in Communications Headsets

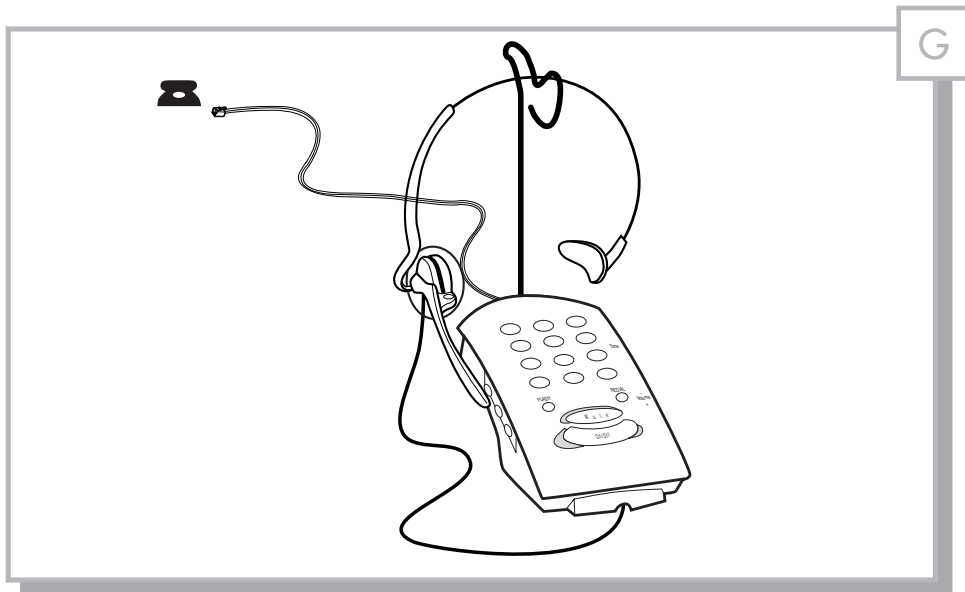
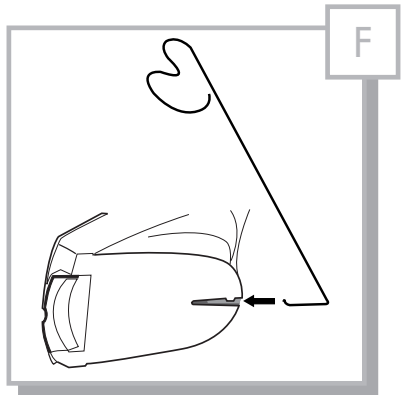
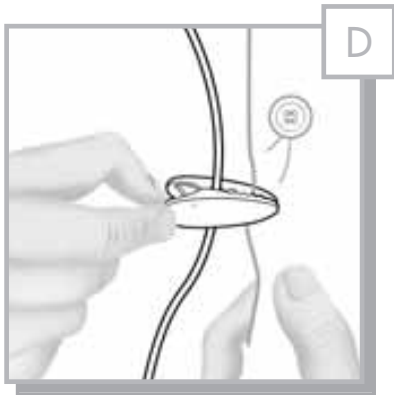
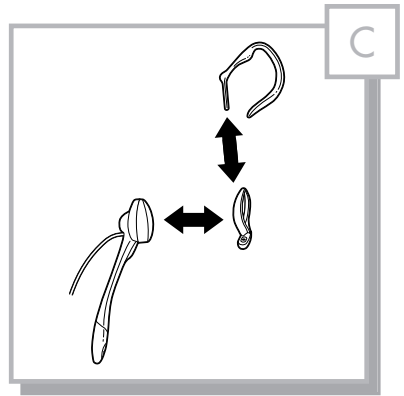
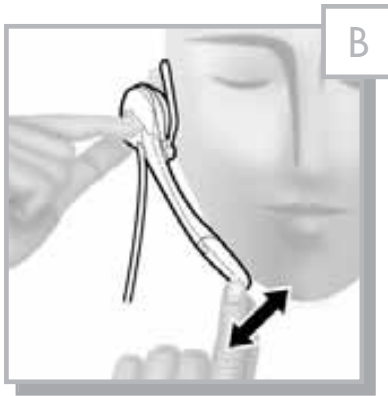
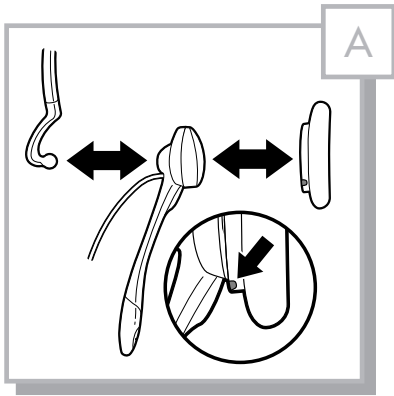

DIAGRAM

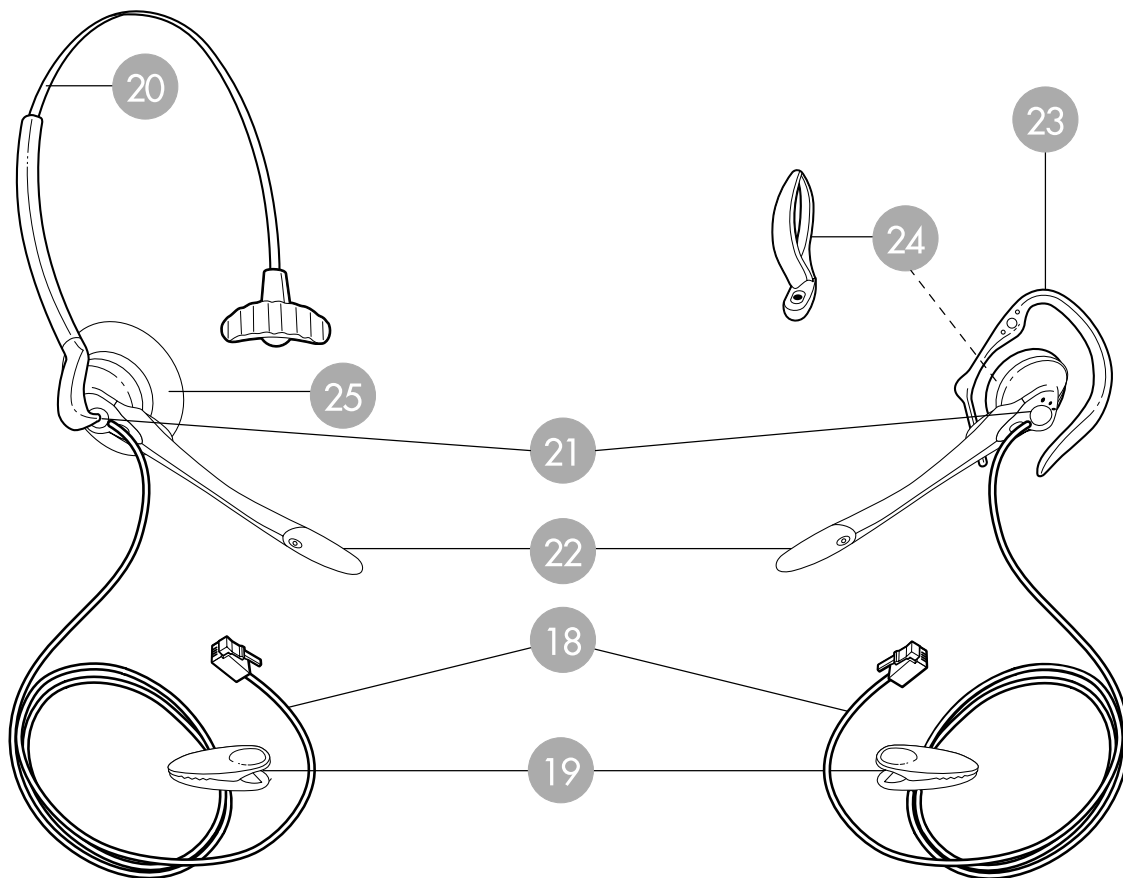
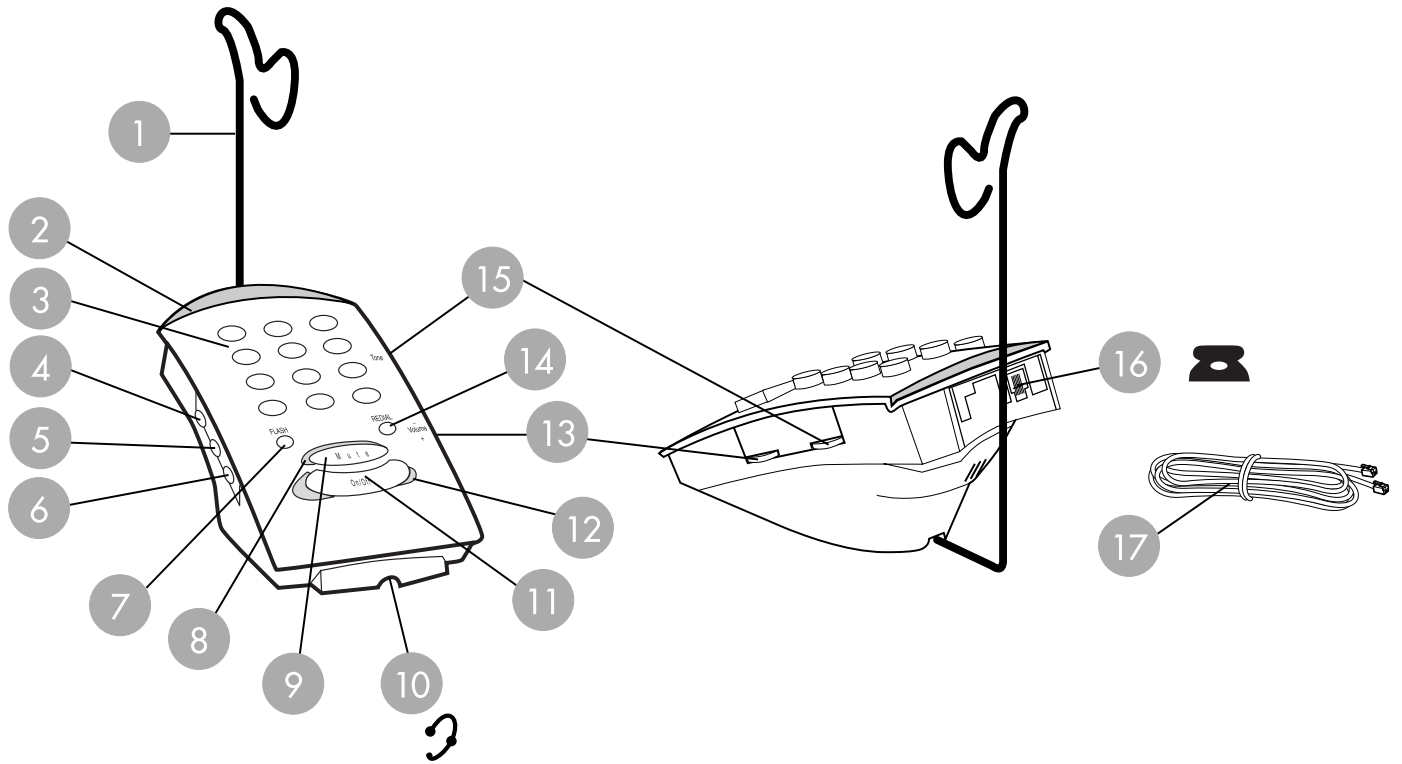

DIAGRAM KEY

Base Front

- 1 Headset Holder
(P/N 46356-01)
- 2 On Line Indicator Light
- 3 Twelve Button Dial Pad
- 4 Flash Timing Switch
- 5 Tone/Pulse Switch
- 6 Ringer Volume Control
- 7 Flash Button
- 8 Mute Indicator Light
- 9 Mute Button
- 10 Headset Jack
- 11 On/Off Button
- 12 In-Use Indicator Light
- 13 Listen Volume Control
- 14 Redial Button
- 15 Tone Control

Base Rear

- 16 Telephone Line Jack
- 17 Line Cord

Headset

(Both Configurations Shown)

- 18 Cord
- 19 Clothing Clip
(P/N 43220-01)
- 20 Adjustable Headband
(P/N 43298-01)
- 21 Headset Assembly
(P/N 45647-04)
- 22 Voice Boom
- 23 Earloops (3 sizes)
(P/N 43297-01)
- 24 Pivot Ball Ring
(P/N 45650-01)
- 25 Ear Cushion Assembly
(P/N 43299-01)

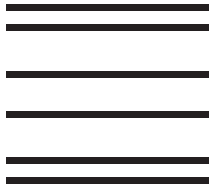

BUSINESS REPLY MAIL
FIRST-CLASS MAIL PERMIT NO. 51 BREA CA

POSTAGE WILL BE PAID BY ADDRESSEE

**PLANTRONICS
PO BOX 9367
BREA CA 92822-8881**

**NO POSTAGE
NECESSARY
IF MAILED
IN THE
UNITED STATES**

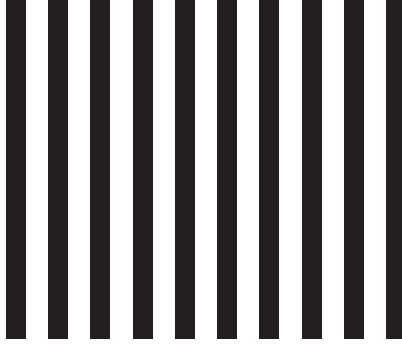

WELCOME

Thank you for selecting the T10 Headset Telephone from Plantronics. This User Guide will help you install your T10 Headset Telephone and learn its basic operation.

IMPORTANT SAFETY INSTRUCTIONS

When using your telephone equipment, basic safety precautions should always be followed to reduce the risk of fire, electric shock, and injury to persons, including the following:

- 1. Read and understand all instructions.**
- 2. Follow all warnings and instructions marked on the product.**
The symbol  identifies and alerts the user to the presence of important operating and service instructions.
- 3. Unplug this product from the wall outlet before cleaning.**
Do not use liquid cleaners or aerosol cleaners. Use a damp cloth for cleaning.
- 4. Do not locate base unit near water,** for example, near a bathtub or sink, in a wet basement, or near a swimming pool.
- 5. Slots and openings in the base unit and the bottom or back are provided for ventilation,** to protect it from overheating; these openings must not be blocked or covered. The openings should never be blocked by placing the product in the bed, sofa, rug or other similar surface. This product should never be placed near or over a radiator or heat register. This product should not be placed in a built-in installation unless proper ventilation is provided.
- 6. This product should be operated only from the low voltage power provided in your telephone line.** No separate power supply is required.

IMPORTANT SAFETY INSTRUCTIONS

- 7. Do not allow anything to rest on the telephone connection cord.** Do not locate this product where the cord will be abused by persons walking on it.
- 8. Do not overload outlets and extension cords as this can result in the risk of fire or electric shock.**
- 9. Never push objects of any kind into this product through base unit slots** as they may touch dangerous voltage points or short out parts that could result in a risk of fire or electric shock. Never spill liquid of any kind on the product.
- 10. To reduce the risk of electric shock, do not disassemble this product,** but take it to qualified service personnel when service or repair work is required. Opening or removing covers may expose you to dangerous voltages or other risks. Incorrect reassembly can cause electric shock when the product is subsequently used.
- 11. Avoid using telephone equipment during an electrical storm.** There may be a remote risk of electric shock from lightning.
- 12. Do not use the telephone equipment to report a gas leak in the vicinity of the leak.**

IMPORTANT SAFETY INSTRUCTIONS

13. Unplug this product from the wall outlet and refer servicing to qualified service personnel under the following conditions:

- a) When the power supply cord or plug is damaged or frayed.
- b) If the product has been exposed to liquid.
- c) If the product does not operate normally by following the operating instructions. Adjust only those controls that are covered by the operating instructions because improper adjustments of other controls may result in damage and will often require extensive work by a qualified technician to restore the product to normal operation.
- d) If the product has been dropped or the base unit has been damaged.
- e) If the product exhibits a distinct change in performance.

14. Never install telephone wiring during a lightning storm.

15. Never install telephone jacks in wet locations unless the jack is specifically designed for wet locations.

16. Never touch uninsulated telephone wires or terminals unless the telephone line has been disconnected at the network interface.

 **17. Use caution when installing or modifying telephone lines.**

18. Keep all product cords and cables away from operating machinery.

STEP 1

SETUP

Connect the Telephone Line Jack¹⁶ to the telephone wall outlet using the Line Cord.¹⁷ **Allow the unit to initialize for 45 seconds before use.**



Turn the T10 base over and insert the Headset Holder.¹

Set the Tone/Pulse Switch⁵ to match your phone service (usually tone). If you are not sure, call your local telephone provider.

Set the Ringer Volume Control⁶ for incoming calls to your preferred level.

Plug the Headset Cord¹⁸ into the Headset Jack.¹⁰

For most U.S. users, the Flash Timing Switch⁴ should be set to "3", however, trying other settings will not harm the T10 or your phone line.

SAVE THESE INSTRUCTIONS

USING THE HEADSET

The Headset included with the T10 Headset Telephone can be used with the Adjustable Headband or with one of the Earloops.

HEADBAND USE

Snap the Adjustable Headband²⁰ into the back of the Headset Assembly²¹. Press the Ear Cushion Assembly²⁵ onto the Headset Assembly²¹, aligning the notch in the ring with the Voice Boom.²²



Place the Headset on either ear and adjust the Headset to a comfortable position by moving the Adjustable Headband.²⁰

Position the Voice Boom²² near the corner of your mouth.



EARLOOP USE

Press the Pivot Ball Ring²⁴ onto the Headset Assembly.²¹



Insert one of the Earloops²³ into the Pivot Ball. You may need to try each size to find the most comfortable fit. Slip the Earloop over your ear and position the Voice Boom near the corner of your mouth.

CLOTHING CLIP

The Clothing Clip¹⁹ keeps the Headset free from the weight of the cord. Attach the clip to your clothing at about chest level. Allow enough slack in the cord (approximately 6 inches) to permit your head to move without pulling on the Headset or the Clothing Clip.



You are now ready to make or receive calls.

PLACING A CALL

With the Headset in position, place a call by pressing the On/Off Button¹¹ (In-use Indicator¹² and On Line Indicator Lights² are on). Listen for dial tone.

E

Dial the desired number using the Twelve Button Dial Pad.³

When your party answers, speak normally. If your party cannot hear you, see **Troubleshooting** (page 12).

Adjust the Listen Volume Control¹³ as needed to hear the other party.

RECEIVING A CALL

With the Headset in position, when the ringer notifies you of an incoming call, press the On/Off Button¹¹ to answer the call (In-use Indicator¹² and On Line Indicator Lights² are on).

REDIAL FEATURE

The base unit will store the last number dialed. The last number can be automatically redialed by pressing the Redial Button. **14**

FLASH FEATURE

If your telephone service includes call waiting, the Flash Button **7** allows you to toggle between two calls. When your phone alerts you to a second call, press the Flash Button **7** to place the current call on hold and to immediately connect you to the second call. Press the Flash Button again to return to the first caller.

This feature can also be used with most office telephone systems to transfer a call to another extension. Press Flash to hear a dial tone, enter the extension number, after the extension rings, press Flash again or hang up to transfer the call.

MUTE FEATURE

When you activate the Mute Button **9**, the calling party cannot hear your voice but you will be able to hear the calling party.

STONE FEATURE

The treble and bass quality of the incoming call can be adjusted by moving the Tone Control. **15**

I CANNOT HEAR A DIAL TONE

Make sure all connections are correct and firmly in place.

Make sure you have pressed the On/Off Button **11** and the In-Use Indicator **12** and On Line Indicator Lights **2** are on.

Adjust Listen Volume Control. **13**

Ensure that Headset is centered on your ear.

Ensure that you have allowed 45 seconds for initialization following first installation.

G

I CANNOT DIAL A NUMBER

Make sure Tone/Pulse Switch Setting is correct. **5**

CALLER CANNOT HEAR MY VOICE

Make sure the Mute Button **9** is turned off with the Mute Indicator Light **8** off.

Adjust Headset so the microphone is closer to your mouth.

PLANTRONICS HELP DESK

The Plantronics Help Desk is ready to assist you!

Dial 1-800-544-4660 Monday through Friday 8:00 a.m. to 5:00 p.m. Pacific Standard Time or visit our website at www.plantronics.com.

SUPPLIES AND ACCESSORIES

For information on supplies and accessories all Plantronics at 1-800-544-4660 or visit our web site at www.plantronics.com. See also Diagram Key for additional part numbers.

FCC REQUIREMENTS—PART 15

This device complies with Part 15 of the FCC Rules. Operation is subject to the following two conditions:

1. This device may not cause harmful interference, and
2. This device must accept any interference received, including interference that may cause undesired operation.

This equipment has been tested and found to comply with the limits for a Class B digital device, pursuant to Part 15 of the FCC Rules. These limits are designed to provide reasonable protection against harmful interference in a residential installation. This equipment generates, uses, and can radiate radio frequency energy and, if not installed and used in accordance with the instructions, may cause harmful interference to radio communications. However, there is no guarantee that interference will not occur in a particular installation. If this equipment does cause harmful interference to radio or television reception which can be determined by turning the radio or television off and on, the user is encouraged to try to correct interference by one or more of the following measures:

1. Reorient or relocate the receiving antenna.
2. Increase the separation between the equipment and receiver.
3. Connect the equipment into an outlet on another circuit.
4. Consult the dealer or an experienced radio/TV technician for help.

RF Exposure Information

This device and its antenna must not be co-located or operated in conjunction with any other antenna or transmitter. To comply with FCC RF exposure requirements, only use supplied antenna. Any unauthorized modification to the antenna or device could void the user's authority to operate this device.

FCC REQUIREMENTS—PART 68

This equipment complies with Part 68 of the FCC Rules. The FCC Part 68 Label is located on the bottom of the unit. This label contains the FCC Registration Number and Ringer Equivalence Number (REN) for this equipment. If requested this information must be provided to your telephone company.

The REN is useful to determine the quantity of devices you may connect to your telephone line and still have all of those devices ring when your telephone number is called. In most, but not all areas, the sum of the RENs of all devices connected to one line should not exceed five (5.0). To be certain of the number of devices you may connect to your line, as determined by the REN, you should contact your local telephone company to determine the maximum REN for your calling area.

Connection to the telephone network should be made by using standard modular telephone jacks, type RJ11. The plug and/or jacks used must comply with FCC

FCC REGISTRATION INFORMATION

Part 68 rules. If this telephone equipment causes harm to the telephone network, the telephone company will notify you in advance that temporary discontinuance of service may be required. But if advance notice isn't practical, the telephone company will notify the customer as soon as possible. Also, you will be advised of your right to file a complaint with the FCC if you believe it is necessary.

The telephone company may make changes in its facilities, equipment, operations or procedures that could affect the proper functioning of your equipment. If they do, you will be notified in advance in order for you to make necessary modifications to maintain uninterrupted service.

NOTE: If your home has specially wired alarm equipment connected to the telephone line, be sure that installing the system does not disable your alarm equipment. If you have questions about what will disable your alarm equipment, contact your telephone company or a qualified installer.

WARRANTY AND SERVICE

LIMITED WARRANTY

for Plantronics Non-commercial Products Purchased in the US and Canada

- This warranty covers defects in materials and workmanship of Commercial Products manufactured, sold or certified by Plantronics which were purchased and used in the United States and Canada.
- This warranty lasts for one year from the date of purchase of the Products.
- This warranty extends to you only if you are the end user with the original purchase receipt.
- We will, at our option, repair or replace the Products that do not conform to the warranty. We may use functionally equivalent reconditioned/refurbished/remanufactured/pre-owned or new Products or parts.
- To obtain service in the U.S. contact Plantronics at (800) 544-4660 and in Canada call (800) 540-8363. If you need additional information, please contact our service centers at the numbers provided.
- THIS IS PLANTRONICS' COMPLETE WARRANTY FOR THE PRODUCTS.
- This warranty gives you specific legal rights, and you may also have other rights which vary from state to state or province to province. Please contact your dealer or our service center for the full details of our limited warranty, including items not covered by this limited warranty.