

User Guide

Remote Handset Lifter (RHL)
GN 1000



For more information and technical specifications:
www.gnnetcom.com

CORPORATE HEADQUARTERS
77 Northeastern Blvd.
Nashua, NH • 03062
1-800-826-4656
1-603-598-1100
Fax: 1-603-598-1122

© 2002 GN Netcom, Inc. • All rights reserved.
54-0314A • Printed in China

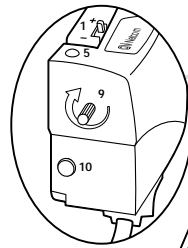

The GN 1000 Remote Handset Lifter, designed exclusively for use with GN Netcom wireless headset systems, lifts the handset from your telephone so you can answer and end calls when away from your desk.

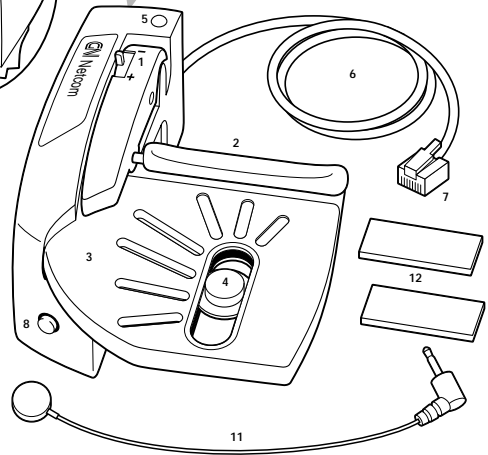

Components

1. Lifter Arm Height Control
2. Lifter Arm
3. Ring Sensor Platform
4. Ring Sensor
5. Ring Sensitivity LED/Online Indicator
6. Power Cord
7. AUX Plug
8. Ring Sensor On/Off Button
9. Ring Sensitivity Knob
10. External Sensor Port
11. External Sensor
12. Velcro

Functions/Indicators

1. **Lifter Arm Height Control:** Position toward the "+" to raise the lifter higher and toward the "-" to lower the lifter if it is too high.
5. **Ring Sensitivity LED/Online Indicator:** Lights when the handset is lifted and you have clear dialtone; flashes when the Ring Sensor Power Button is disabled.
8. **Ring Sensor On/Off Button:** Press to disable the Ring Sensor if using the speakerphone when your phone is connected to a wireless headset Beltpack system.

Setting Up

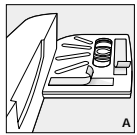

1. Affix the Ring Sensor Platform to the telephone.
 - A. Remove the protective backing from the adhesive pads on the bottom of the Ring Sensor Platform (Velcro is provided as an alternate securing option).

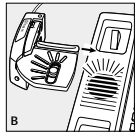

- B. Locate your telephone's speaker (in most cases it is located under the telephone's handset).



- C. Align the top of the Platform with the bottom edge of the telephone hookswitch well and locate the Ring Sensor to position it over the telephone's speaker. Affix the Platform firmly to your telephone. Slide the Ring Sensor to position it over the middle of the telephone speaker.

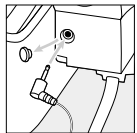

2. If your telephone's speaker is not under the handset, use the External Sensor. Remove the rubber cover and plug the External Sensor into the External Sensor Port. Peel the tape backing off the External Ring Sensor and attach it over the speaker.



3. Connect the Remote Handset Lifter to your wireless system. Insert the AUX Plug into the large port marked AUX on the base of your wireless headset system (you will need to remove the Stand to access this port).*



4. Put your headset on.

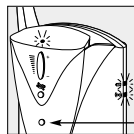

5. Press the Handset Lifter Button* on your Beltpack or Headset to put the wireless system in Headset Mode and activate the Lifter. The Lifter may take a moment to respond.



6. The Lifter Arm will raise the handset and you will hear dialtone. The Ring Sensitivity LED lights while your handset is lifted and you have clear dialtone.

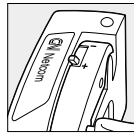

7. If you do not hear dialtone, adjust the height of the Lifter Arm by moving the Height Control towards "+" to raise the arm. Moving the Height Control towards "-" lowers the arm.



8. Adjust the Ring Sensor Sensitivity by turning the knob clockwise to increase the sensitivity and counterclockwise to decrease the sensitivity. While the phone is ringing, turn the knob until the Ring Sensor LED lights. Stop turning as soon as the LED lights for optimal performance.

Using the System

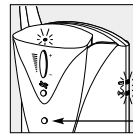

1. When you hear a ring tone from your Beltpack (Beltpack systems only) or in your Headset, press the Handset Lifter Button on your wireless system's remote device.

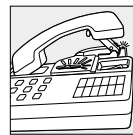

2. The Remote Handset Lifter lifts your handset and connects the call through your handset.

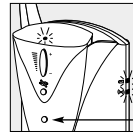

3. To lower the Lifter and handset to end the call, press the Handset Lifter Button on your Beltpack or Headset.
 - When using a non-Beltpack wireless headset, hold the Handset Lifter Button down for 2-3 seconds.

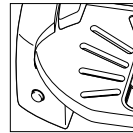

4. When using the speakerphone feature on your telephone, press the Ring Sensor On/Off Button to disable it. When disabled, the Ring Sensitivity LED rapidly flashes.

Frequently Asked Questions

What should I do if the Remote Handset Lifter is not lifting the handset?

- Check the cable connection between the Lifter and the base of your wireless headset system.
- Make sure there is power to the wireless system.

What should I do if I can't hear the dial tone?

- The Lifting Arm height may need to be slightly higher. Move the Height Control toward the "+" to raise the arm higher.
- If the Remote Handset Lifter is installed on a key system telephone (where you have to push a button to connect to a line), the "Auto Line Selector" feature of your phone system must be reprogrammed. Refer to the instructions that came with your phone system.

What should I do if I hear a signal in my headset, but no call comes through?

- The Ring Sensor may be picking up electronic "noise," such as a computer monitor, fluorescent desk lamp, etc.
- Lower the Ring Sensor's sensitivity by turning the adjustment knob counterclockwise.

What should I do if calls are coming in, but I don't hear a signal in my headset or from my beltpack?

- Make sure the Ring Sensor On/Off Button is on. If the red Ring Sensitivity LED is flashing, the Ring Sensor is off. Press the button on the front of the Lifter to reactivate.
- Make sure the Ring Sensor is located over the telephone's speaker.
- Adjust the Ring Sensor's sensitivity. While the phone is ringing, turn the Ring Sensitivity Knob until the Ring Sensor LED lights. Stop turning as soon as LED lights for best performance.

What should I do if my Online Indicator doesn't light when I'm on a call?

- Adjust the Ring Sensor's sensitivity. While on a call, turn the Ring Sensitivity Knob clockwise (only slightly) until the light comes on.

How do I stop my Headset/Beltpack from signaling I have a call when I use my telephone's speakerphone?

- Turn the Ring Sensor off (the LED will flash rapidly when off). Turn it back on when you've finished your speakerphone call.

* Refer to the instructions that came with your wireless headset system for location of buttons and functions.